

Economizer Check-Out Procedures



In-The-Field Tool

Honeywell

To check out the operation of the W7220:

Use the Checkout menu in the table below to test the damper operation and any configured outputs. Only items that are configured are shown in the Checkout menu.

1. Scroll to the desired test in the Checkout menu using the ▲ and ▼ buttons.
2. Press the ↵ button to select the item.
3. RUN? appears.
4. Press the ↵ button to start the test.
5. The unit pauses and then displays IN PROGRESS.
6. When the test is complete, DONE appears.
7. When all parameters have been tested, press the ⏴ button (Menu up) to end the test (e.g. turn off the relay).

The checkout tests can all be performed at the time of installation or any time during the operation of the system.

Checkout Menu

Checkout Item	Checkout Test
DAMPER VMIN-HS	Positions damper to VMIN position
DAMPER VMAX-HS	Positions damper to VMAX position
DAMPER OPEN	Positions damper to the full open position. Exhaust fan contacts enable during the DAMPER OPEN test. Make sure you pause in this mode to allow for exhaust contacts to energize due to the delay in the system.
DAMPER CLOSE	Positions damper to the fully closed position.
CONNECT Y1-O	Closes the Y1-O relay (Y1-O). See CAUTION on this page
CONNECT Y2-O	Closes the Y2-O relay (Y2-O). See CAUTION on this page
CONNECT AUX	Energizes the AUX output. If Aux setting is: <ul style="list-style-type: none">• NONE – no action taken• ERV – 24 Vac out. Turns on or signals an ERV that the conditions are not good for economizing but are good for ERV operation.^a• SYS – 24 Vac out. Issues a system alarm.

^a ERV Operation: When in Cooling mode AND the conditions are NOT OK for economizing - the ERV terminal will be energized. In the Heating mode the ERV terminal will be energized when the OA is below the ERV OAT setpoint in the setpoint menu.

CAUTION

Equipment damage may result.

Be sure to allow enough time for compressor startup and shutdown between checkout tests so that you do not short-cycle the compressors.

To check out the operation of the W7212, W7213 or W7214:

1. Remove the MAT or DAT sensor from T-T1.
2. Remove the jumper from P-P1 and place it on T-T1.
3. Remove the OAT and RAT sensors from SO and SO+ and SR and SR+.
4. Place a 620 ohm resistor across SO and SO+ and a 620 ohm resistor across SR and SR+.
5. Connect the actuator to the + and -.
6. Provide 24 Vac to TR and TR1.
7. Provide 24 Vac hot to terminal 1.

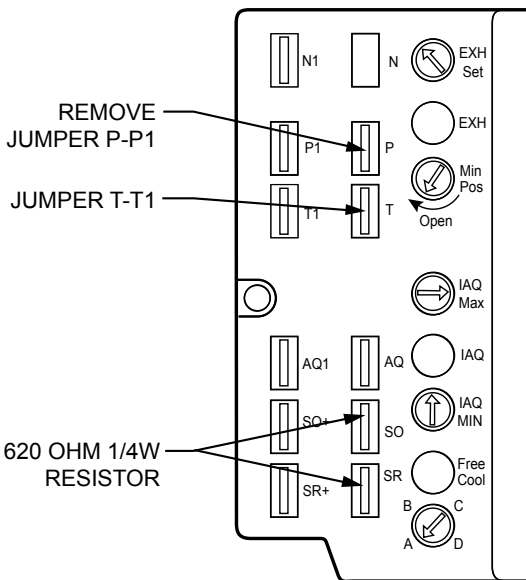

8. The motor will drive open.
9. Remove the 24 Vac from TR and TR1 and the motor should drive close.

If using DCA, the + on the logic module will be connected to 3 and does not need to be connected to — since the actuators are internally connected to ground.

If using two transformers make sure the transformers are tied to the same COM and are from the same power source.

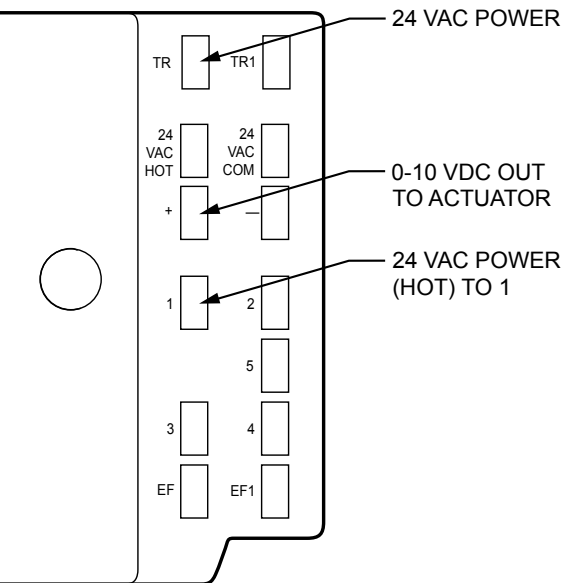

To check out the procedure for Sylk sensor and analog sensors connected to W7220:

1. Go to status menu on W7220 and scroll through sensors validating that the temperature and humidity readings are correct.
2. If sensor reading does not match the measured reading from a calibrated sensor – go to the Advanced Set Up menu and scroll to the sensor calibration item and press enter and change sensor input using up and down arrows. This adds an offset in the W7220 software for the sensor. When changing the sensor – sensor may need re-calibration. Sensors that can be offset are: MAT, OAT, OAH, RAT, RAH, and DAT.



To check out the operation of the W7459:

Set Enthalpy Changeover Setpoint Pot to D

1. Disconnect power from TR and TR1.
2. Disconnect jumper P to P1.

For W7459A and D

3. Jumper TR to 1.
4. Jumper T1 to T.

For W7459B

3. Jumper M1 to 3.
4. Jumper M2 to 2.

For W7459C

3. Disconnect 6, X and D.
4. Jumper 6 to D.
5. Remove OAT from SO and +.
6. Place a 620 ohm resistor across SR and +.
7. LED is off.
8. Apply 24 Vac to TR and TR1.
9. Motor is in closed position.
10. Disconnect 620 ohm resistor from SR to +.
11. LED turns on and motor drives toward open.
12. Jumper 620 ohm resistor from SR to +.
13. Jumper 1.2K ohm 4074EJM from SO to +.
14. Turn pot to A.
15. LED Turns on and motor drives toward open.
16. Turn pot to D.
17. LED turns off and motor drives toward closed.
18. Disconnect 1.2K ohm resistor.
19. Jumper + of OA sensor to + of W7459.
20. Connect meter to SO of W7459 and S of enthalpy sensor.
21. Meter reads between 3 and 25 mA.



To check out the operation of the C7400 enthalpy sensors:

(You must have an accurate reading of the ambient temperature and humidity.)

1. Connect C7400 sensors to SO and SO+ and to SR and SR+.
2. To check the return air C7400 sensor on SR and SR+: Measure the voltage across SR and ground (any terminal followed by a 1 e.g., T1, P1).
3. To check the outdoor air C7400 sensor on SO and SO+: Measure the voltage across SO and ground (any terminal followed by a 1 e.g., T1, P1).
4. Find the line on the chart on pages 9 and 10 for return air C7400 sensor that corresponds to the voltage you read across SR and ground. It should intersect with the humidity and temperature of your ambient conditions. There is a ± 0.3 Vdc range for the sensor accuracy, and above 90% RH the accuracy changes to ± 0.4 Vdc.
5. DO NOT USE THE LINES ON THIS CHART; USE THE DATA IN THE TABLE. MAKE SURE TO USE THE CORRECT TABLE FOR SO AND THE CORRECT TABLE FOR SR. The values differ due to the logic module requirement for the choice between the two sensors for differential enthalpy.
6. MAKE SURE YOU USE THE CORRECT TABLE FOR THE C7400A OR C7400C SENSORS.

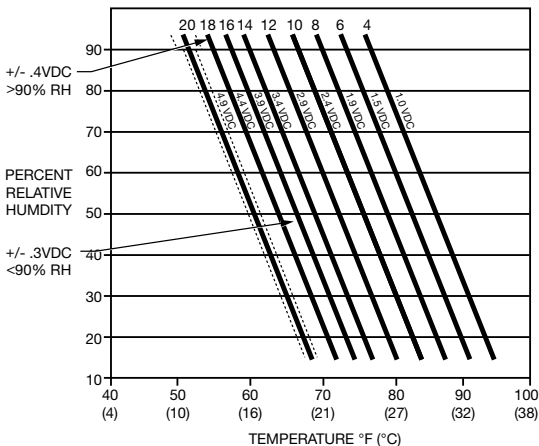

SO C7400A CHECK
 C7400A SO AND GND VDC

SO	Vdc me			
<90% RH				
mA curve	4	6	8	10
Low (-.3 Vdc)	0.672	1.158	1.644	2.13
Nominal	0.972	1.458	1.944	2.43
High (+.3 Vdc)	1.272	1.758	2.244	2.73
> 90% RH				
mA curve	4	6	8	10
Low (-.4 Vdc)	0.572	1.058	1.544	2.03
Nominal	0.972	1.458	1.944	2.43
High (+.4 Vdc)	1.372	1.858	2.344	2.83

Sr	Vdc me			
<90% RH				
mA curve	4	6	8	10
Low (-.3 Vdc)	0.72	1.23	1.74	2.25
Nominal	1.02	1.53	2.04	2.55
High (+.3 Vdc)	1.32	1.83	2.34	2.85
> 90% RH				
mA curve	4	6	8	10
Low (-.4 Vdc)	0.62	1.13	1.64	2.15
Nominal	1.02	1.53	2.04	2.55
High (+.4 Vdc)	1.42	1.93	2.44	2.95

NOTE: The accuracy of the sensors used to measure the temperature and h
 If you are close to the measurements your C7400 sensor is probably

SR C7400A CHECK
C7400A SO AND GND VDC

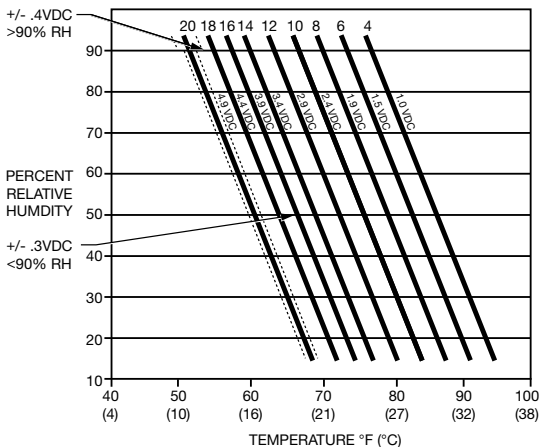

measured between SO and GND

	12	14	16	18	20
	2.616	3.102	3.588	4.074	4.56
	2.916	3.402	3.888	4.374	4.86
	3.216	3.702	4.188	4.674	5.16
	12	14	16	18	20
	2.516	3.002	3.488	3.974	4.46
	2.916	3.402	3.888	4.374	4.86
	3.316	3.802	4.288	4.774	5.26

measured between Sr and GND

	12	14	16	18	20
	2.76	3.27	3.78	4.29	4.8
	3.06	3.57	4.08	4.59	5.1
	3.36	3.87	4.38	4.89	5.4
	12	14	16	18	20
	2.66	3.17	3.68	4.19	4.7
	3.06	3.57	4.08	4.59	5.1
	3.46	3.97	4.48	4.99	5.5

humidity of the environment needs to be considered.
working.

SO C7400C CHECK

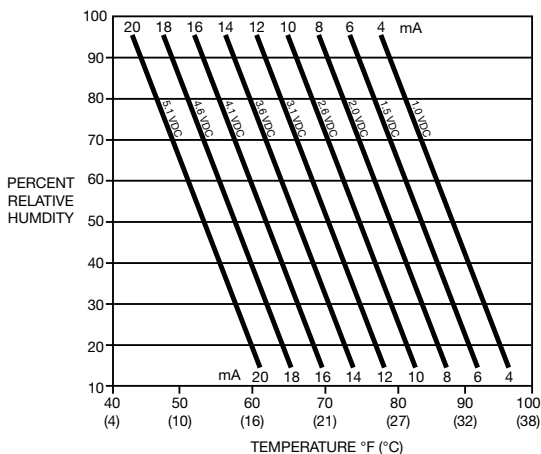

SO	Vdc mA			
<90% RH				
mA curve	4	6	8	10
Low (-.3 Vdc)	0.672	1.158	1.644	2.13
Nominal	0.972	1.458	1.944	2.43
High (+.3 Vdc)	1.272	1.758	2.244	2.73
> 90% RH				
mA curve	4	6	8	10
Low (-.4 Vdc)	0.572	1.058	1.544	2.03
Nominal	0.972	1.458	1.944	2.43
High (+.4 Vdc)	1.372	1.858	2.344	2.83

Sr	Vdc mA			
<90% RH				
mA curve	4	6	8	10
Low (-.3 Vdc)	0.72	1.23	1.74	2.25
Nominal	1.02	1.53	2.04	2.55
High (+.3 Vdc)	1.32	1.83	2.34	2.85
> 90% RH				
mA curve	4	6	8	10
Low (-.4 Vdc)	0.62	1.13	1.64	2.15
Nominal	1.02	1.53	2.04	2.55
High (+.4 Vdc)	1.42	1.93	2.44	2.95

NOTE: The accuracy of the sensors used to measure the temperature and h
If you are close to the measurements your C7400 sensor is probably

SR C7400C CHECK

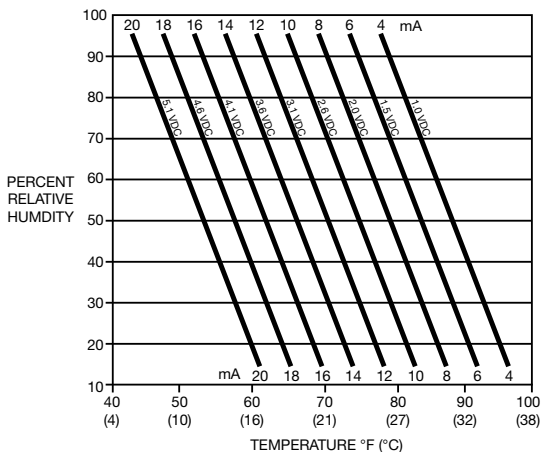

Measured between SO and GND

	12	14	16	18	20
	2.616	3.102	3.588	4.074	4.56
	2.916	3.402	3.888	4.374	4.86
	3.216	3.702	4.188	4.674	5.16
	12	14	16	18	20
	2.516	3.002	3.488	3.974	4.46
	2.916	3.402	3.888	4.374	4.86
	3.316	3.802	4.288	4.774	5.26

Measured between Sr and GND

	12	14	16	18	20
	2.76	3.27	3.78	4.29	4.8
	3.06	3.57	4.08	4.59	5.1
	3.36	3.87	4.38	4.89	5.4
	12	14	16	18	20
	2.66	3.17	3.68	4.19	4.7
	3.06	3.57	4.08	4.59	5.1
	3.46	3.97	4.48	4.99	5.5

humidity of the environment needs to be considered.
working.

Automation and Control Solutions

In the U.S.:

Honeywell

1985 Douglas Drive North

Golden Valley, MN 55422-3992

In Canada:

Honeywell Limited

35 Dynamic Drive

Toronto, Ontario M1V 4Z9

In Latin America:

Honeywell

9315 N.W. 112th Avenue

Miami, FL 33178

www.honeywell.com

Honeywell

63-9730

January 2011

© 2011 Honeywell International Inc.