

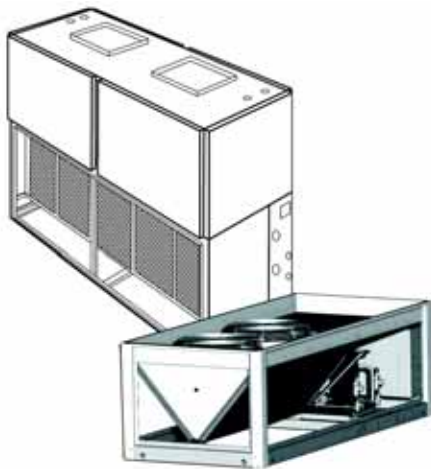

## TECHNICAL GUIDE

### COMMERCIAL SPLIT-SYSTEM COOLING UNITS FOUR PIPE SYSTEM

MODELS HB 180 & HB 240  
MODELS LB 180 & LB 240  
15 & 20 NOMINAL TONS  
9.7 EER



## GENERAL SPECIFICATIONS

### OUTDOOR UNIT:

- Two independent refrigerant circuits
- Inherently protected fan motors
- Two independent scroll compressors
- V-Coil Design
- Exterior service port connections
- Refrigerant-22 holding charge
- Five-minute compressor anti-short cycle timer
- Two independent control circuits
- Compressor operation to 40°F
- Field-installed Low Ambient VFD Control to 0°F
- Five-year limited warranty on compressor
- One-year limited warranty on all other parts
- Simplicity Controls
- Factory installed disconnect and Technicoat coils

### INDOOR UNIT:

- Factory-mounted expansion valve and filter-drier in both refrigerant circuit
- Adjustable TXV's
- Two-inch throwaway filters
- Single point power connection
- One-year limited warranty on all parts
- Field installed drive packages



## TABLE OF CONTENTS

<b>GENERAL SPECIFICATIONS</b> .....	<b>1</b>
<b>OUTDOOR UNIT</b> .....	<b>1</b>
<b>INDOOR UNIT</b> .....	<b>1</b>
<b>DESCRIPTION</b> .....	<b>3</b>
<b>APPLICATION FLEXIBILITY OUTDOOR</b> .....	<b>3</b>
<b>APPLICATION FLEXIBILITY INDOOR</b> .....	<b>3</b>
<b>OUTDOOR UNIT</b> .....	<b>4</b>
<b>ACCESSORIES (FACTORY &amp; FIELD INSTALLED)</b> .....	<b>4</b>
<b>INDOOR UNIT</b> .....	<b>5</b>
<b>ACCESSORIES INDOOR UNIT (FIELD INSTALLED)</b> .....	<b>5</b>
<b>GUIDE SPECIFICATIONS</b> .....	<b>24</b>

### LIST OF FIGURES

<u>Fig. #</u>	<u>Pg. #</u>
1 TYPICAL INDOOR UNIT APPLICATIONS .....	3
2 INDOOR PRODUCT NOMENCLATURE .....	4
3 INDOOR PRODUCT NOMENCLATURE .....	5
4 VERTICAL ARRANGEMENTS - LB180 AND LB240 ..	6
5 HORIZONTAL ARRANGEMENTS - LB180 AND LB240 .....	6
6 CORNER WEIGHT .....	9
7 PIPING AND ELECTRICAL CONNECTION LOCATIONS .....	10
8 15 TON BLOWER PERFORMANCE .....	19
9 20 TON BLOWER PERFORMANCE .....	19
10 HORIZONTAL APPLICATION CORNER WEIGHTS ..	21
11 VERTICAL APPLICATION CORNER WEIGHTS ....	21
12 UNIT DIMENSIONS LB180 AND LB240 .....	22
13 LB180 SUPPLY AIR PLENUM DIMENSIONS .....	23
14 RETURN AIR GRILLE FOR LB180 DIMENSIONS ...	23

### LIST OF TABLES

<u>Tbl. #</u>		<u>Pg. #</u>
1	UNIT APPLICATION DATA .....	7
2	ARI RATINGS - COOLING AND SOUND .....	7
3	ELECTRICAL DATA COMPRESSORS .....	7
4	ELECTRICAL DATA FAN MOTORS .....	7
5	ELECTRICAL DATA, OUTDOOR MCA & MAX. FUSE SIZE .....	7
6	OUTDOOR UNIT PHYSICAL DATA .....	8
7	INDOOR UNIT PHYSICAL DATA .....	8
8	CONNECTIONS .....	9
9	UNIT CLEARANCES .....	9
10	HB CORNER WEIGHTS AND CENTER OF GRAVITY	9
11	PIPING AND ELECTRICAL CONNECTION SIZES ..	10
12	REFRIGERANT LINE CHARGE .....	11
13	SUCTION LINES .....	12
14	LIQUID LINES .....	12
15	15 TON CAPACITY TABLE - 85° AND 95°F .....	13
16	15 TON CAPACITY TABLE - 105° AND 115°F .....	14
17	15 TON CAPACITY TABLE - 125°F .....	15
18	20 TON CAPACITY TABLE - 85° AND 95°F .....	16
19	20 TON CAPACITY TABLE - 105° & 115°F .....	17
20	20 TON CAPACITY TABLE - 125°F .....	18
21	LB180 15 TON AIRFLOW TABLE .....	18
22	LB240 20 TON AIRFLOW TABLE .....	18
23	BLOWER DRIVE DATA .....	20
24	BLOWER DATA .....	20
25	INDOOR ELECTRICAL RATINGS .....	20
26	INDOOR UNIT WEIGHTS AND CORNER WEIGHTS	21
27	UNIT DIMENSIONS LB180 AND LB240 .....	22

## DESCRIPTION

Both the outdoor and indoor units are completely piped and wired at the factory and are shipped ready for immediate installation. Only the interconnecting liquid and suction lines, control wiring, and the main power wiring are required to complete the installation. Every outdoor unit is dehydrated, evacuated, leak tested and pressure tested at 450 psig before being pressurized with a holding charge of refrigerant-22 for shipment and/or storage.

To eliminate the costly cabinet deterioration problems usually associated with outdoor equipment, all sheet metal parts are constructed of commercial grade (G90) galvanized steel. After fabrication, each part is thoroughly cleaned to remove any grease or dirt from its surfaces. The parts that will be exposed to the weather are then coated with a desert sand powder paint to assure a quality finish for many years. This coating system has passed the 750-hour, salt spray test per ASTM Standard B117.

## APPLICATION FLEXIBILITY OUTDOOR

The outdoor units are lightweight and can be installed on almost any roof.

Units can be lifted using nylon straps with hooks at the holes provided in the base rails, or they may be lifted with a forklift through the slotted openings in the base rails.

A quality appearance and low sound levels make these units suitable for most ground level locations.

## APPLICATION FLEXIBILITY INDOOR

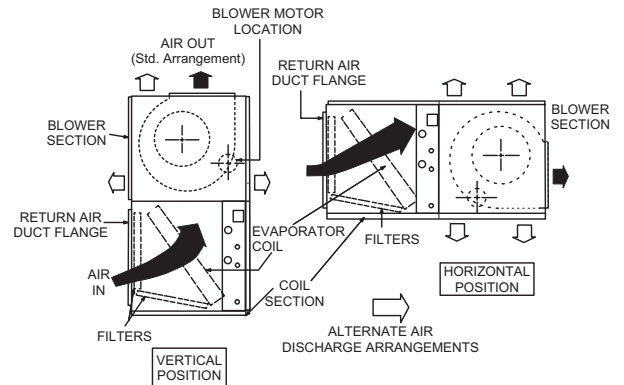

NOTE: CERTAIN BLOWER POSITIONS ARE NOT RECOMMENDED. BECAUSE THE BLOWER MOTOR SHOULD NOT BE MOUNTED UPSIDE DOWN.

**FIGURE 1 - TYPICAL INDOOR UNIT APPLICATIONS**

The indoor units are built in a single cabinet with one condensate drain pan. These units can be installed in either the vertical or horizontal position for maximum flexibility.

- NOTE:** On vertical applications, the air velocity across the indoor coil keeps the condensate from dripping off the finned surface onto the filters.
- NOTE:** On horizontal applications the unit must be installed with the condensate drain pan under the entire indoor coil.
- NOTE:** The Supply Air Plenum and the Return Air Grille accessories can be used on either arrangement.
- NOTE:** The Base accessory can only be used on the vertical arrangement.

## CONDENSER ONLY CAPACITY

Model HB	Suction Press. &		Temperature of Air on Condenser Coil, °F											
			65		75		85		95		105		115	
	PSIG	°F	MBH	KW*	MBH	KW*	MBH	KW*	MBH	KW*	MBH	KW*	MBH	KW*
240	61.5	35	255	17.2	243	18.6	231	20.1	219	21.9	207	23.9	195	26.2
	68.5	40	275	17.6	263	19.0	250	20.6	238	22.4	225	24.4	212	26.7
	76	45	296	18.1	283	19.5	270	21.1	257	22.9	243	24.9	230	27.2
	84	50	319	18.7	305	20.0	291	21.6	277	23.4	263	25.5	248	27.7
180	61.5	35	191	12.7	182	13.7	172	14.9	163	16.2	153	17.7	143	19.4
	68.5	40	207	13.0	197	14.0	187	15.2	177	16.5	167	18.0	157	19.8
	76	45	224	13.3	214	14.4	203	15.5	193	16.9	182	18.4	171	20.2
	84	50	241	13.7	230	14.7	219	15.9	208	17.3	197	18.8	186	20.6

\*Power consumption includes outdoor fans and compressors only.

FIGURE 2 - INDOOR PRODUCT NOMENCLATURE

**YORK INDOOR PRODUCT NOMENCLATURE**  
**H A 120 C 00 A 2 A A A 1 A**

Model #	Model Number Description	Options
H	Product Category	H = Air Conditioner Split System      E = Heat Pump Split System
A	Product Identifier	A = R-22 Standard Efficiency 2-Pipe B = R-22 Standard Efficiency 4-Pipe
120	Nominal Cooling Capacity MBH	090 = 7-1/2 Ton                              300 = 25 Ton * 120 = 10 Ton                                    360 = 30 Ton * 150 = 12-1/2 Ton                              480 = 40 Ton * 180 = 15 Ton                                    600 = 50 Ton *
C	Heat Type	C = Cooling Only
00	Nominal Heating Capacity	00 = No Heat Installed
A	Airflow Options	A = Standard Motor
2	Voltage	2 = 208/230-3-600                              5 = 575-3-60 4 = 460-3-60
A	Installation Options	A = None B = Disconnect
AA	Additional Options	AA = None AC = Technicoat Coil
1	Product Generation	1 = 1 <sup>st</sup> Generation                              2 = 2 <sup>nd</sup> Generation
A	Product Style	A = Style A    B = Style B

\*NOT AVAILABLE IN HEAT PUMP

## OUTDOOR UNIT

Every unit includes 2 heavy-duty scroll compressors, 2 outdoor fan motors with inherent protection, subfusing and a copper tube/aluminum fin coil.

All controls are located in the front of the unit in the control box and are readily accessible for maintenance, adjustment and service. All wiring (power and control) can be made through the front of the unit.

## ACCESSORIES (FACTORY & FIELD INSTALLED)

- Factory installed Non-Fused Disconnect for safety and convenience.
- Factory installed Technicoat Condenser Coils for corrosion protection.
- Field Installed VFD (Variable Frequency Drive) for Low Ambient operation down to 0°F.
- Field Installed Hot Gas Bypass for low load operation.
- Field installed Pump-Out Kit for applications where liquid slugging could be an issue.

**FIGURE 3 - INDOOR PRODUCT NOMENCLATURE****YORK INDOOR PRODUCT NOMENCLATURE****L A 120 C 00 A 2 A A A 1 A**

Model #	Model Number Description	Options
L	Product Category	L = Air Handling Unit- Cooling      F = Air Handling Unit- Heat Pump
A	Product Identifier	A = R-22 Standard Efficiency 2-Pipe B = R-22 Standard Efficiency 4-Pipe
120	Nominal Cooling Capacity MBH	090 = 7-1/2 Ton      300 = 25 Ton * 120=10 Ton      360 = 30 Ton * 150 = 12-1/2 Ton      480 = 40 Ton * 180 = 15 Ton      600 = 50 Ton *
C	Heat Type	C = Cooling Only
00	Nominal Heating Capacity	00 = No Heat Installed
2	Voltage	0 = None      6= 208/230-460-3-60 5 = 575-3-60
A	Factory Options	A = None
AA	Special Options	AA = None
1	Generation	1 = First Generation      2 = Second Generation
A	Style	A = Style A      B = Style B

**INDOOR UNIT**

Every unit includes a well-insulated cabinet, copper tube/aluminum fin coil with interlaced circuiting arrangement, 2" throwaway filters, adjustable TXV's and centrifugal blowers. Blower motors and drive kits are ordered separately. **Power wiring for blower motor is field supplied.**

The controls include 208/230/460 or 575 volt transformer, blower motor contactor and relay, and a low voltage terminal block.

The units are shipped in the vertical position ready for field installation. For horizontal installation, the blower module can be repositioned in the field as shown on pages 3 and 6 for maximum flexibility.

**ACCESSORIES INDOOR UNIT (FIELD INSTALLED)**

- Supply Air Plenums and Return Air Grilles (expanded metal) accessories are available for free-standing indoor

(15 Ton units only) units located in the conditioned space. Both accessories are finished to match the exterior of the basic unit, and both can be applied with either vertical or horizontal units. The supply air plenums are fully insulated and have double-deflection, adjustable grilles.

- Base Sections are available to raise vertical indoor units above the floor. Outdoor air may be introduced through these bases by cutting an access opening for the outdoor air duct connection. These bases are finished to match the exterior of the basic unit. They may have to be insulated in the field for certain applications.
- Suspension Kit is available for indoor units installed horizontally.
- Manual and electronic two stage thermostats are available for cooling applications.
- Both thermostats have a two-position fan switch, AUTO and ON to provide intermittent or continuous blower operation.

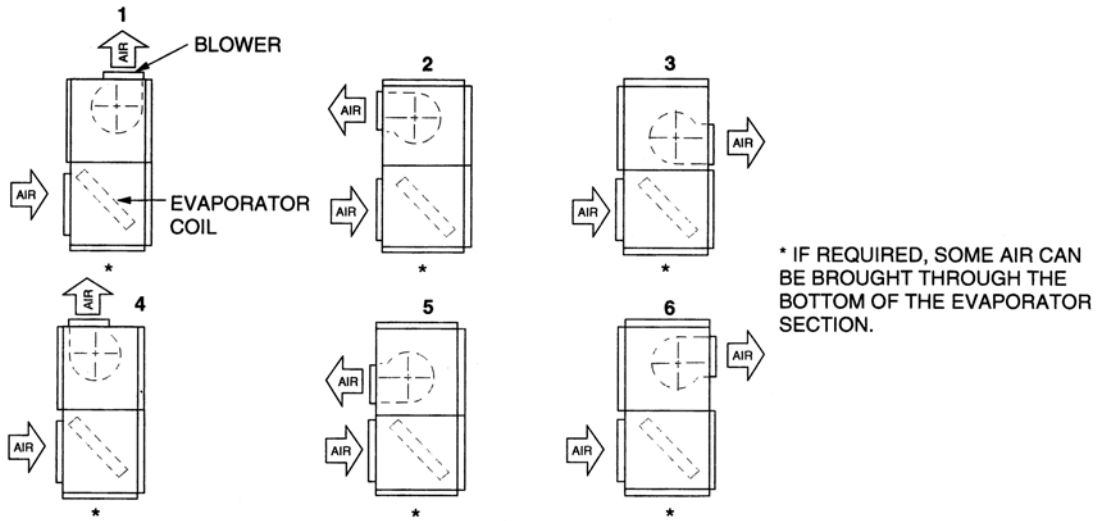

FIGURE 4 - VERTICAL ARRANGEMENTS - LB180 AND LB240

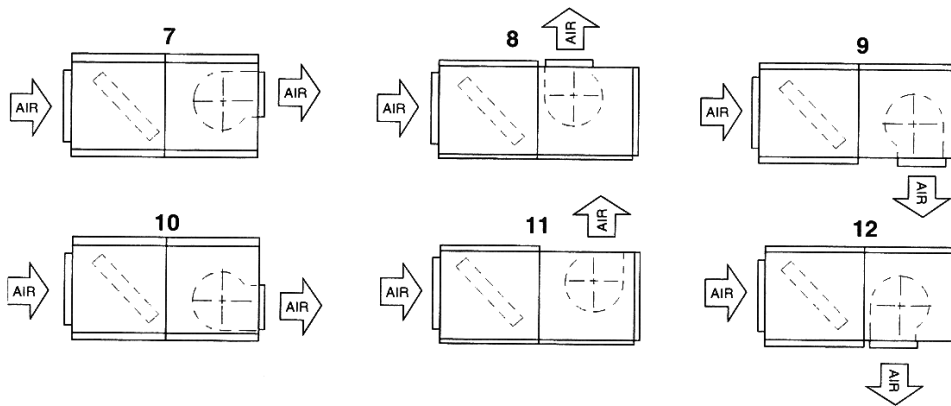



FIGURE 5 - HORIZONTAL ARRANGEMENTS - LB180 AND LB240

 <b>CAUTION</b>
<p>CERTAIN BLOWER POSITIONS ARE NOT RECOMMENDED BECAUSE THE BLOWER MOTOR SHOULD NOT BE MOUNTED UPSIDE DOWN.</p>

**TABLE 1: UNIT APPLICATION DATA**

Application Limitations	Minimum	Maximum
Voltage Variation (208/230-3-60) - Volts	187	253
Voltage Variation (460-3-60) - Volts	414	506
Voltage Variation (575-3-60) - Volts	540	630
Ambient Air on Outdoor Coil (Cooling Cycle) - °F	45	115
Ambient Air on Indoor Coil (Cooling Cycle) - °F	68	86

**TABLE 2: ARI RATINGS - COOLING AND SOUND**

Model		Cooling Capacity <sup>1</sup>			Cond. Unit Sound <sup>2</sup>	Rated Airflow	Rated ESP
Outdoor Unit	Indoor Unit	MBH	EER	IPLV	dB	CFM	IWG
HB180	LB180	180	9.7	10.4	89.0	6000	0.35
HB240	LB240	240	9.7	10.4	90.0	8000	0.40

1. Ratings are in accordance with ARI standard 340/360.
2. Ratings are in accordance with ARI standard 370.

**TABLE 3: ELECTRICAL DATA COMPRESSORS**

Model Number	Compressors				
	Power Supply	System 1		System 2	
		RLA	LRA	RLA	LRA
HB180	208/230-3-60	25.6	190.0	25.6	190.0
HB180	460-3-60	12.8	95.0	12.8	95.0
HB180	575-3-60	10.2	75	10.2	75
HB240	208/230-3-60	42.0	239.0	42.0	239.0
HB240	460-3-60	19.2	125.0	19.2	125.0
HB240	575-3-60	13.8	80	13.8	80

**TABLE 4: ELECTRICAL DATA FAN MOTORS**

Model Number	Condenser Fans		
	Power Supply	Qty.	FLA ea.
HB180	208/230-3-60	2	3.7
HB180	460-3-60	2	1.85
HB180	575-3-60	2	1.7
HB240	208/230-3-60	2	5.8
HB240	460-3-60	2	2.9
HB240	575-3-60	2	2.2

**TABLE 5: ELECTRICAL DATA, OUTDOOR MCA & MAX. FUSE SIZE**

Model Number	Power Supply	Min. Circuit Ampacity	Max. Fuse Size <sup>1</sup>
HB180	208/230-3-60	65.1	90
HB180	460-3-60	32.5	45
HB180	575-3-60	26.4	35
HB240	208/230-3-60	106.1	125
HB240	460-3-60	49.0	60
HB240	575-3-60	35.5	45

1. Maximum fuse or maximum circuit breaker (HACR type per NEC).

TABLE 6: OUTDOOR UNIT PHYSICAL DATA

Description		Unit Model	
		HB180	HB240
<b>Compressor<sup>1</sup></b>	Rating - (Qty) Tons	2 X 7.5 = 15 Tons	2 X 10 = 20 Tons
	Quantity	2	2
<b>Fans</b>	Diameter - inches	24	24
	Blades/Pitch (°)	3/34	3/32
	Nominal CFM	12,400	11,400
	HP	1	1.5
<b>Fan Motors<sup>2</sup></b>	RPM	1140	1100
	Rows Deep X Rows High	2 X 30	2 X 30
<b>Coil</b>	Finned Length - inches each slab	60	78
	Face Area - square feet (both slabs)	25	32.5
	Tube(Copper) OD - inches	3/8	3/8
	Fins(Aluminum) per inch	16	16
	Holding Charge (sys1/sys2) <sup>3</sup>	1 - 0 / 1 - 0 lbs.	1 - 0 / 1 - 0 lbs.
<b>Refrigerant - 22 (lbs -oz.)</b>	Operating Charge (sys1/sys2) <sup>4</sup>	14.0/14.0 lbs.	17.0/17.0 lbs.
	Shipping	944	1380
<b>Unit Weight (lbs)</b>	Operating	957	1396

1. These compressors are fully hermetic.
2. The ball bearing, 56 frame, single phase condenser fan motors have internal protection and are directly connected to the condenser fans. Motor rotation is counterclockwise when viewing the lead end, which is opposite the shaft end.
3. The amount of charge in the unit as shipped from the factory.
4. Total operating charge for the condensing unit, matching indoor unit, and 25 feet of interconnecting pipe.

TABLE 7: INDOOR UNIT PHYSICAL DATA

Description		Unit Model		
		LB180	LB240	
<b>Coil</b>	Rows Deep X Rows High	3 X 32	3 X 40	
	Finned length- Inches	83	81	
	Face Area - Square Feet	18.4	22.5	
	Tube (Copper) OD - Inches	3/8	3/8	
	Fins (Aluminum) per Inch	13	16	
<b>Centrifugal Blower (Forward Curve - Qty)</b>	Diameter X Width - Inches	15 X 12 - 2	18 X 18 - 2	
<b>Blower Motor<sup>1</sup></b>	HP	Field Installed		
	RPM	--	--	
<b>Filters (Throwaway)</b>	Quantity Per Unit	4/4	10	
	Size - Inches	20 X 21 X 2 & 22 X 24 X 2	20 X 25 X 2	
	Total Face Area - Square Feet	25.8	34.7	
<b>Unit Weight (lbs)</b>	Shipping	720	990	
	Operating	830	1115	
<b>Accessory Operating Weight (lbs)</b>	Motor & Drive	3HP	47	--
		5HP	120	120
	Supply Air Plenum	185	N/A	
	Return Air Grille	25	N/A	
	Base	140	210	

1. Refer to Table 23 and 25 for more information.



All dimensions are in inches. They are subject to change without notice. Certified dimensions will be provided upon request.

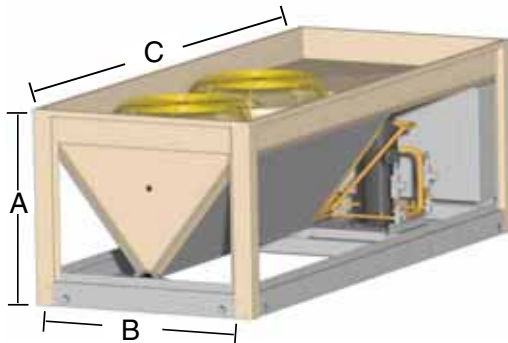

**OUTDOOR UNIT DIMENSIONS**

Unit	Dimensions (In.)		
	A	B	C
15 Ton	37.5	45.75	110.5
20 Ton	37.5	45.75	128.1

**TABLE 8: CONNECTIONS**

Connection Entry	Connection Size	
	15 Ton <sup>1</sup>	20 Ton <sup>1</sup>
Suction Line	1-1/8 ID	1-3/8 ID
Liquid Line	5/8 ID	5/8 ID
Power Wiring	2-1/8 KO	2-1/8 KO
Control Wiring	7/8 KO	7/8 KO

1. Refer to Tables 13 and 14 for appropriate suction and liquid line sizes.

**TABLE 9: UNIT CLEARANCES**

Location	Dimensions
Overhead (Top) <sup>1</sup>	120"
Front access panels	36"
Left Side	30"
Right Side	30"
Rear	24"
Bottom <sup>2</sup>	0"

1. Units must be installed outdoors. Overhanging structures or shrubs should not obstruct condenser air discharge.  
 2. Adequate snow clearance must be provided if winter operation is expected.

**TABLE 10: HB CORNER WEIGHTS AND CENTER OF GRAVITY**

UNIT SIZE	SHIPPING WEIGHT	OPERATING WEIGHT	A	B	C	D	UNIT LENGTH	UNIT WIDTH	DIM X	DIM Y
15 Ton Outdoor	944	959	205	275	275	205	110	46	47	23
20 Ton Outdoor	1124	1141	232	339	339	232	128	46	52	23

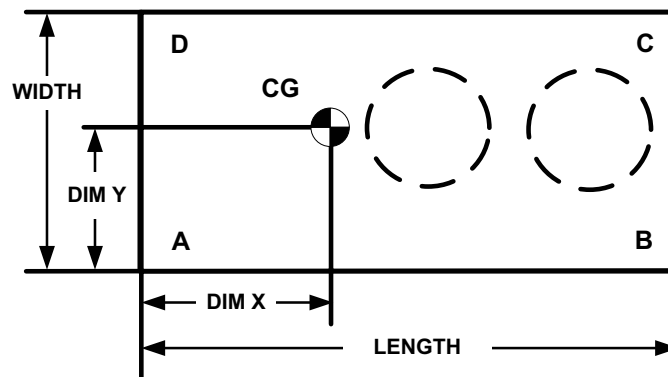

**FIGURE 6 - CORNER WEIGHT**

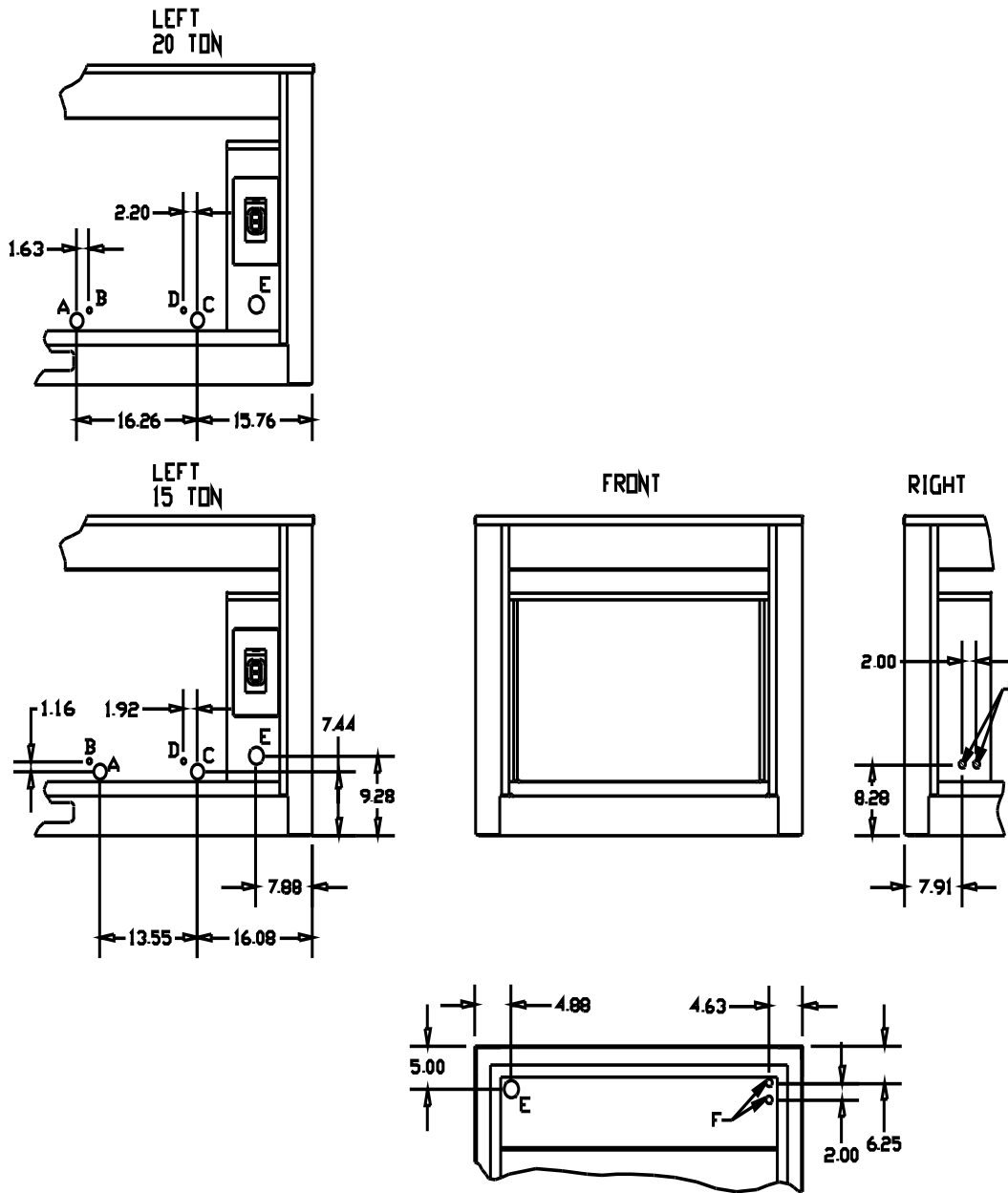

FIGURE 7 - PIPING AND ELECTRICAL CONNECTION LOCATIONS

TABLE 11: PIPING AND ELECTRICAL CONNECTION SIZES

CONNECTION ENTRY		SIZE
A	SUCTION LINE SYS. #1	1-1/8 ID (15 Ton); 1-3/8 ID (20 Ton)
B	LIQUID LINE SYS. #1	5/8 ID
C	SUCTION LINE SYS. #2	1-1/8 ID (15 Ton); 1-3/8 ID (20 Ton)
D	LIQUID LINE SYS. #2	5/8 ID
E	POWER WIRING	2" KO
F	CONTROL WIRING	7/8 KO

## REFRIGERANT PIPING

### GENERAL GUIDELINES

Many service problems can be avoided by taking adequate precautions to provide an internally clean and dry system and by using procedures and materials that conform with established standards.

Use hard drawn copper tubing where no appreciable amount of bending around pipes or other obstructions is necessary. Use long radius ells wherever possible with one exception - small radius elbows for the traps in all vapor risers. If soft copper is used, care should be taken to avoid sharp bends which may cause a restriction.

Pack fiber glass insulation and a sealing material such as permagum around refrigerant lines where they penetrate a wall to reduce vibration and to retain some flexibility.

Support all refrigerant lines at minimum intervals with suitable hangers, brackets or clamps.

Insulate all vapor lines with a minimum of 1/2" ARMA-FLEX or equal. Liquid lines exposed to direct sunlight and/or high temperatures must also be insulated.

Never solder vapor and liquid lines together. They can be taped together for convenience and support purposes, but they must be completely insulated from each other.

### LINE SIZING

When sizing refrigerant lines for a split-system air conditioner, check the following:

1. Suction line pressure drop due to friction at full capacity,
2. Liquid line pressure drop due to friction at full capacity,

3. Suction line velocity for oil return at part capacity, and
4. Liquid line pressure drop due to static head.

**NOTE:** Never base refrigerant line sizes on the OD of the suction and liquid connections on the unit.

Tables 13 and 14 list friction losses for both the suction and liquid lines on the system. Table 12 shows the amount of refrigerant charge required per foot of refrigerant line.

When the evaporator coil is below the condensing unit, the suction line must be sized for both pressure drop and for oil return. For certain piping arrangements, different suction line sizes may have to be used. The velocity of the suction gas must always be great enough to carry oil back to the compressor.

When the condensing unit is below the evaporator coil, the liquid line must be designed for the pressure drop due to both friction loss and vertical rise. If the total pressure drop exceeds 40 psi, some refrigerant may flash before it reaches the thermal expansion valve. This flashing will not only cause erratic valve operation and poor system performance, but could also damage the expansion valve.

**TABLE 12: REFRIGERANT LINE CHARGE<sup>1</sup>**

Refrigerant Line <sup>2</sup>	Line Size O.D. (in.)	Refrigerant Charge (lb./ft.)
Liquid	5/8	0.113
Vapor	1-1/8	0.013
	1-3/8	

1. Charges are based on 40°F suction temperature and 105°F liquid temperature.
2. Type "L" copper tubing.

**TABLE 13: SUCTION LINES<sup>1 2</sup>**

Model Designation			Nominal Capacity (Tons)	Refrigerant Flow Rate <sup>3</sup> (Lbs./Min.)	Copper Tubing (Inches, O.D.)	Refrigerant Gas Velocity (Ft./Min.)	Friction Loss <sup>4</sup> <sub>5</sub> (PSI/100 Ft.)
HL-15	4-Pipe System	System # 1	7 1/2	24.6	1 1/8	2050	4.3
					1 3/8	1680	1.6
					1 5/8	1140	0.7
	System # 2	7 1/2	24.6	1 1/8	2050	4.3	
				1 3/8	1680	1.6	
				1 5/8	1140	0.7	
HL-20	4-Pipe System	System # 1	10	32.5	1 1/8	3500	8.0
					1 3/8	2280	2.8
					1 5/8	1560	1.2
	System # 2	10	32.5	1 1/8	3500	8.0	
				1 3/8	2280	2.8	
				1 5/8	1560	1.2	

1. All horizontal suction lines should be pitched at least 1 inch every 20 feet in the direction of the refrigerant flow to aid the return of oil to the compressor.
2. Every vertical suction riser greater than 25 feet in height should have a "P" trap at the bottom to facilitate the return of oil to the compressor. Use short radius fittings for these traps.
3. Based on Refrigerant-22 at the nominal capacity of the condensing unit, a saturated suction temperature of 45°F and a liquid temperature of 110°F.
4. Although suction lines should be sized for a friction loss equivalent to a 2°F change in saturation temperature (or approximately 3psi), sizing the lines for the proper return of oil is more important.
5. These friction losses do not include any allowances for valves or fittings.

**TABLE 14: LIQUID LINES**

Model Designation			Nominal Capacity (Tons)	Refrigerant Flow Rate <sup>1</sup> (Lbs./Min.)	Copper Tubing (Inches, O.D.)	Friction Loss <sup>2 3</sup> (PSI/100 Ft.)	Vertical Rise (PSI/Ft.)
HL-15	4-Pipe System	System # 1	7 1/2	24.6	1/2	11.0	0.5
					5/8	3.5	0.5
		System #2	7 1/2	24.6	1/2	11.0	0.5
					5/8	3.5	0.5
HL-20	4-Pipe System	System #1	10	32.5	5/8	5.8	0.5
					3/4	2.3	0.5
		System # 2	10	32.5	5/8	5.8	0.5
					3/4	2.3	0.5

1. Based on Refrigerant-22 at the nominal capacity of the condensing unit, a saturated suction temperature of 45°F and a liquid temperature of 110°F.
2. The total pressure drop of the liquid line for both friction and vertical rise must not exceed 40 PSI. If the pressure drop exceeds 40 PSI, the liquid refrigerant could flash before it reaches the expansion valve. This flashing will not only cause erratic valve operation and poor system performance, but could also damage the expansion valve.
3. These friction losses do not include any allowances for a strainer, filter-drier, solenoid valve, isolation valve or fittings.

**TABLE 15: 15 TON CAPACITY TABLE - 85° AND 95°F**

15 Ton Capacity Tables										
HB180 Matched with LB180										
AIR ON EVAPORATOR				OUTDOOR AMBIENT TEMPERATURE (F): <b>85°</b>						
CFM	W.B.	GROSS	INPUT	86	GROSS SENSIBLE CAPACITY (MBh)					
	TEMP	CAP.	POWER		(RETURN AIR DRY BULB TEMP.- (F))					
	(F)	(MBh)	(kW)		83	80	77	74	71	68
4500	72	197.8	15.23	117.3	104.5	91.6	78.8	66.0	#N/A	#N/A
	67	183.8	14.90	144.8	131.9	119.1	106.3	93.4	80.6	67.8
	62	170.5	14.50	168.2	155.4	142.6	129.8	116.9	104.1	91.3
	57	173.8	14.43	173.8	171.0	158.2	145.3	132.5	119.7	106.9
5250	72	204.1	15.34	129.7	114.5	99.4	84.2	69.0	#N/A	#N/A
	67	189.6	15.01	159.4	144.3	129.1	114.0	98.8	83.6	68.5
	62	175.9	14.60	174.8	168.3	154.6	139.4	124.3	109.1	93.9
	57	179.3	14.53	179.3	177.9	171.5	156.3	141.2	126.0	110.8
6000	72	210.3	15.44	142.1	124.6	107.1	89.6	72.1	#N/A	#N/A
	67	195.4	15.12	174.1	156.6	139.1	121.6	104.1	86.6	69.2
	62	181.3	14.70	181.3	181.3	166.6	149.1	131.6	114.1	96.6
	57	184.8	14.64	184.8	184.8	184.8	167.3	149.8	132.3	114.8
6750	72	213.6	15.54	152.3	132.4	112.5	92.6	72.6	#N/A	#N/A
	67	198.4	15.21	186.0	166.1	146.2	126.3	106.3	86.4	66.5
	62	184.0	14.80	184.0	184.0	175.0	155.1	135.2	115.3	95.3
	57	187.6	14.73	187.6	187.6	187.6	167.7	147.8	127.8	107.9
7500	72	216.8	15.64	162.6	140.3	117.9	95.6	73.2	#N/A	#N/A
	67	201.4	15.31	198.0	175.6	153.3	130.9	108.5	86.2	63.8
	62	186.8	14.89	186.8	186.8	183.5	161.1	138.8	116.4	94.1
	57	190.5	14.82	190.5	190.5	190.5	168.1	145.7	123.4	101.0

Indicates Nominal Capacity Rating Point.

INPUT POWER INCLUDES THE CONDENSER AND COMPRESSOR MOTORS BUT NOT THE INDOOR BLOWER MOTOR

15 Ton Capacity Tables										
HB180 Matched with LB180										
AIR ON EVAPORATOR				OUTDOOR AMBIENT TEMPERATURE (F): <b>95°</b>						
CFM	W.B.	GROSS	INPUT	86	GROSS SENSIBLE CAPACITY (MBh)					
	TEMP	CAP.	POWER		(RETURN AIR DRY BULB TEMP.- (F))					
	(F)	(MBh)	(kW)		83	80	77	74	71	68
4500	72	190.9	16.89	114.1	101.3	88.5	75.7	62.8	#N/A	#N/A
	67	176.8	16.51	142.2	129.4	116.5	103.7	90.9	78.0	65.2
	62	162.8	16.18	162.8	153.2	140.3	127.5	114.7	101.8	89.0
	57	163.2	16.11	163.2	158.1	145.2	132.4	119.6	106.7	93.9
5250	72	196.2	16.99	126.2	111.0	95.8	80.7	65.5	#N/A	#N/A
	67	181.7	16.61	156.5	141.4	126.2	111.0	95.9	80.7	65.6
	62	167.4	16.27	167.4	162.5	152.0	136.8	121.6	106.5	91.3
	57	167.7	16.20	167.7	165.2	157.3	142.1	127.0	111.8	96.6
6000	72	201.5	17.09	138.2	120.7	103.2	85.7	68.2	#N/A	#N/A
	67	186.6	16.71	170.9	153.4	135.9	118.4	100.9	83.4	65.9
	62	171.9	16.37	171.9	171.9	163.6	146.1	128.6	111.1	93.6
	57	172.3	16.30	172.3	172.3	169.3	151.8	134.4	116.9	99.4
6750	72	205.1	17.17	148.4	128.5	108.6	88.6	68.7	#N/A	#N/A
	67	190.0	16.79	182.1	162.9	143.0	123.1	103.1	83.2	63.3
	62	175.0	16.45	175.0	175.0	170.9	150.9	131.0	111.1	91.2
	57	175.4	16.37	175.4	175.4	173.9	154.0	134.1	114.2	94.2
7500	72	208.8	17.25	158.7	136.3	114.0	91.6	69.2	#N/A	#N/A
	67	193.4	16.86	193.4	172.4	150.1	127.7	105.4	83.0	60.7
	62	178.1	16.52	178.1	178.1	178.1	155.7	133.4	111.0	88.7
	57	178.5	16.45	178.5	178.5	178.5	156.2	133.8	111.4	89.1

Indicates Nominal Capacity Rating Point.

INPUT POWER INCLUDES THE CONDENSER AND COMPRESSOR MOTORS BUT NOT THE INDOOR BLOWER MOTOR

**TABLE 16: 15 TON CAPACITY TABLE - 105° AND 115°F**

15 Ton Capacity Tables										
HB180 Matched with LB180										
AIR ON EVAPORATOR				OUTDOOR AMBIENT TEMPERATURE (F): <b>105°</b>						
CFM	W.B.	GROSS	INPUT	86	GROSS SENSIBLE CAPACITY (MBh)					
	TEMP	CAP.	POWER		(RETURN AIR DRY BULB TEMP.- (F))					
	(F)	(MBh)	(kW)		83	80	77	74	71	68
4500	72	182.8	18.89	111.9	99.1	86.2	73.4	60.6	#N/A	#N/A
	67	168.9	18.42	139.2	126.3	113.5	100.7	87.8	75.0	62.2
	62	156.1	18.00	156.1	150.4	137.6	124.7	111.9	99.1	86.2
	57	157.8	17.99	157.8	152.5	139.7	126.8	114.0	101.2	88.3
5250	72	187.6	19.03	123.6	108.5	93.3	78.1	63.0	#N/A	#N/A
	67	173.4	18.56	153.1	137.9	122.8	107.6	92.4	77.3	62.1
	62	160.2	18.13	160.2	157.4	148.8	133.6	118.5	103.3	88.1
	57	162.0	18.13	162.0	159.3	151.1	135.9	120.7	105.6	90.4
6000	72	192.4	19.17	135.3	117.8	100.3	82.8	65.3	#N/A	#N/A
	67	177.8	18.70	167.0	149.5	132.0	114.6	97.1	79.6	62.1
	62	164.3	18.27	164.3	164.3	160.0	142.5	125.0	107.5	90.1
	57	166.1	18.26	166.1	166.1	162.5	145.0	127.5	110.0	92.5
6750	72	196.1	19.23	146.1	126.2	106.2	86.3	66.4	#N/A	#N/A
	67	181.2	18.76	175.9	159.8	139.8	119.9	100.0	80.1	60.1
	62	167.5	18.33	167.5	167.5	165.4	145.4	125.5	105.6	85.7
	57	169.3	18.32	169.3	169.3	167.5	147.6	127.7	107.7	87.8
7500	72	199.8	19.30	156.9	134.5	112.2	89.8	67.4	#N/A	#N/A
	67	184.7	18.82	184.7	170.0	147.6	125.3	102.9	80.5	58.2
	62	170.7	18.39	170.7	170.7	170.7	148.3	126.0	103.6	81.3
	57	172.5	18.38	172.5	172.5	172.5	150.2	127.8	105.5	83.1
Indicates Nominal Capacity Rating Point.										
INPUT POWER INCLUDES THE CONDENSER AND COMPRESSOR MOTORS BUT NOT THE INDOOR BLOWER MOTOR										

15 Ton Capacity Tables										
HB180 Matched with LB180										
AIR ON EVAPORATOR				OUTDOOR AMBIENT TEMPERATURE (F): <b>115°</b>						
CFM	W.B.	GROSS	INPUT	86	GROSS SENSIBLE CAPACITY (MBh)					
	TEMP	CAP.	POWER		(RETURN AIR DRY BULB TEMP.- (F))					
	(F)	(MBh)	(kW)		83	80	77	74	71	68
4500	72	174.7	20.88	109.7	96.8	84.0	71.2	58.3	#N/A	#N/A
	67	161.0	20.33	136.1	123.3	110.5	97.6	84.8	72.0	59.1
	62	149.4	19.81	149.4	147.6	134.8	122.0	109.1	96.3	83.5
	57	152.5	19.88	152.5	146.9	134.1	121.2	108.4	95.6	82.8
5250	72	179.0	21.06	121.1	105.9	90.8	75.6	60.4	#N/A	#N/A
	67	165.0	20.51	149.7	134.5	119.3	104.2	89.0	73.9	58.7
	62	153.1	19.99	153.1	152.2	145.6	130.5	115.3	100.1	85.0
	57	156.2	20.05	156.2	153.4	144.8	129.7	114.5	99.4	84.2
6000	72	183.3	21.25	132.5	115.0	97.5	80.0	62.5	#N/A	#N/A
	67	168.9	20.69	163.2	145.7	128.2	110.7	93.2	75.7	58.2
	62	156.8	20.16	156.8	156.8	156.5	139.0	121.5	104.0	86.5
	57	159.9	20.23	159.9	159.9	155.6	138.1	120.6	103.1	85.6
6750	72	187.1	21.30	143.8	123.9	103.9	84.0	64.1	#N/A	#N/A
	67	172.4	20.73	169.6	156.6	136.7	116.8	96.8	76.9	57.0
	62	160.0	20.21	160.0	160.0	159.9	139.9	120.0	100.1	80.2
	57	163.2	20.27	163.2	163.2	161.1	141.2	121.2	101.3	81.4
7500	72	190.9	21.34	155.1	132.7	110.4	88.0	65.7	#N/A	#N/A
	67	175.9	20.78	175.9	167.5	145.1	122.8	100.4	78.1	55.7
	62	163.3	20.25	163.3	163.3	163.3	140.9	118.5	96.2	73.8
	57	166.6	20.32	166.6	166.6	166.6	144.2	121.8	99.5	77.1
Indicates Nominal Capacity Rating Point.										
INPUT POWER INCLUDES THE CONDENSER AND COMPRESSOR MOTORS BUT NOT THE INDOOR BLOWER MOTOR										

**TABLE 17: 15 TON CAPACITY TABLE - 125°F**

15 Ton Capacity Tables										
HB180 Matched with LB180										
AIR ON EVAPORATOR				OUTDOOR AMBIENT TEMPERATURE (F): <b>125°</b>						
CFM	W.B.	GROSS	INPUT	86	GROSS SENSIBLE CAPACITY (MBh)					
	TEMP	CAP.	POWER		(RETURN AIR DRY BULB TEMP.- (F))					
	(F)	(MBh)	(kW)		83	80	77	74	71	68
4500	72	166.6	22.9	107.4	94.6	81.8	68.9	56.1	#N/A	#N/A
	67	153.1	22.2	133.1	120.3	107.4	94.6	81.8	68.9	56.1
	62	142.7	21.6	142.7	142.7	132.0	119.2	106.4	93.5	80.7
	57	147.1	21.8	147.1	141.3	128.5	115.7	102.8	90.0	77.2
5250	72	170.4	23.1	118.5	103.4	88.2	73.1	57.9	#N/A	#N/A
	67	156.6	22.5	146.2	131.1	115.9	100.8	85.6	70.4	55.3
	62	146.0	21.8	146.0	146.0	142.5	127.3	112.1	97.0	81.8
	57	150.4	22.0	150.4	147.6	138.6	123.5	108.3	93.1	78.0
6000	72	174.2	23.3	129.7	112.2	94.7	77.2	59.7	#N/A	#N/A
	67	160.1	22.7	159.4	141.9	124.4	106.9	89.4	71.9	54.4
	62	149.2	22.1	149.2	149.2	149.2	135.4	117.9	100.4	82.9
	57	153.8	22.2	153.8	153.8	148.8	131.3	113.8	96.3	78.8
6750	72	178.0	23.4	141.5	121.5	101.6	81.7	61.8	#N/A	#N/A
	67	163.6	22.7	163.3	153.5	133.5	113.6	93.7	73.8	53.8
	62	152.5	22.1	152.5	152.5	152.5	134.4	114.5	94.6	74.7
	57	157.2	22.2	157.2	157.2	154.7	134.7	114.8	94.9	75.0
7500	72	181.9	23.4	153.3	130.9	108.6	86.2	63.9	#N/A	#N/A
	67	167.2	22.7	167.2	165.0	142.7	120.3	98.0	75.6	53.2
	62	155.8	22.1	155.8	155.8	155.8	133.5	111.1	88.8	66.4
	57	160.6	22.3	160.6	160.6	160.6	138.2	115.9	93.5	71.2
Indicates Nominal Capacity Rating Point.										
INPUT POWER INCLUDES THE CONDENSER AND COMPRESSOR MOTORS BUT NOT THE INDOOR BLOWER MOTOR										

**TABLE 18: 20 TON CAPACITY TABLE - 85° AND 95°F**

20 Ton Capacity Tables										
HB240 & LB240										
AIR ON EVAPORATOR				OUTDOOR AMBIENT TEMPERATURE (F): <b>85°</b>						
CFM	W.B.	GROSS	INPUT	GROSS SENSIBLE CAPACITY (MBh)						
	TEMP	CAP.	POWER	(RETURN AIR DRY BULB TEMP.- (F))						
	(F)	(MBh)	(kW)	86	83	80	77	74	71	68
6000	72	263.4	21.25	155.9	138.8	121.7	104.6	87.5	#N/A	#N/A
	67	243.5	20.69	191.0	173.9	156.8	139.7	122.6	105.5	88.4
	62	227.6	20.42	221.1	204.0	186.9	169.8	152.7	135.6	118.5
	57	219.5	20.19	219.5	216.7	199.6	182.5	165.4	148.3	131.2
7000	72	273.9	21.38	172.8	152.6	132.4	112.2	91.9	#N/A	#N/A
	67	253.2	20.82	211.0	190.8	170.6	150.3	130.1	109.9	89.7
	62	236.7	20.54	233.4	223.5	203.3	183.1	162.9	142.6	122.4
	57	228.2	20.31	228.2	226.8	217.1	196.9	176.7	156.4	136.2
8000	72	284.4	21.51	189.7	166.4	143.0	119.7	96.4	#N/A	#N/A
	67	262.9	20.94	231.0	207.6	184.3	161.0	137.6	114.3	91.0
	62	245.7	20.67	245.7	243.0	219.7	196.3	173.0	149.7	126.4
	57	237.0	20.43	237.0	237.0	234.6	211.3	187.9	164.6	141.3
8600	72	289.0	21.64	197.6	172.2	146.8	121.5	96.1	#N/A	#N/A
	67	267.2	21.06	239.9	214.6	189.2	163.8	138.4	113.0	87.7
	62	249.7	20.79	249.7	248.3	225.5	200.1	174.7	149.4	124.0
	57	240.8	20.55	240.8	240.8	239.6	214.2	188.9	163.5	138.1
9200	72	293.6	21.76	205.5	178.0	150.6	123.2	95.8	#N/A	#N/A
	67	271.4	21.19	248.9	221.5	194.1	166.6	139.2	111.8	84.4
	62	253.7	20.91	253.7	253.7	231.3	203.9	176.5	149.0	121.6
	57	244.6	20.67	244.6	244.6	244.6	217.2	189.8	162.4	134.9

Indicates Nominal Capacity Rating Point.

INPUT POWER INCLUDES THE CONDENSER AND COMPRESSOR MOTORS BUT NOT THE INDOOR BLOWER MOTOR

20 Ton Capacity Tables										
HB240 & LB240										
AIR ON EVAPORATOR				OUTDOOR AMBIENT TEMPERATURE (F): <b>95°</b>						
CFM	W.B.	GROSS	INPUT	GROSS SENSIBLE CAPACITY (MBh)						
	TEMP	CAP.	POWER	(RETURN AIR DRY BULB TEMP.- (F))						
	(F)	(MBh)	(kW)	86	83	80	77	74	71	68
6000	72	253.7	23.11	151.3	134.2	117.0	99.9	82.8	#N/A	#N/A
	67	237.2	22.68	188.2	171.1	153.9	136.8	119.7	102.6	85.5
	62	218.5	22.16	218.5	202.7	185.6	168.5	151.4	134.3	117.2
	57	214.5	22.11	214.5	210.5	193.4	176.3	159.1	142.0	124.9
7000	72	262.8	23.30	167.5	147.3	127.1	106.8	86.6	#N/A	#N/A
	67	245.7	22.88	207.5	187.3	167.1	146.9	126.7	106.5	86.2
	62	226.4	22.35	226.4	218.5	201.5	181.3	161.0	140.8	120.6
	57	222.2	22.30	222.2	220.2	209.9	189.7	169.5	149.2	129.0
8000	72	271.9	23.50	183.7	160.4	137.1	113.7	90.4	#N/A	#N/A
	67	254.3	23.07	226.9	203.6	180.3	156.9	133.6	110.3	87.0
	62	234.2	22.54	234.2	234.2	217.3	194.0	170.7	147.4	124.0
	57	229.9	22.49	229.9	229.9	226.4	203.1	179.8	156.4	133.1
8600	72	269.7	23.60	189.5	164.1	138.7	113.3	88.0	#N/A	#N/A
	67	252.2	23.16	233.2	207.8	182.4	157.1	131.7	106.3	80.9
	62	232.3	22.63	232.3	232.3	220.0	194.6	169.2	143.8	118.5
	57	228.0	22.58	228.0	228.0	226.3	200.9	175.5	150.2	124.8
9200	72	267.6	23.69	195.2	167.8	140.4	112.9	85.5	#N/A	#N/A
	67	250.2	23.26	239.5	212.0	184.6	157.2	129.8	102.3	74.9
	62	230.4	22.72	230.4	230.4	222.6	195.2	167.7	140.3	112.9
	57	226.2	22.68	226.2	226.2	226.2	198.7	171.3	143.9	116.5

Indicates Nominal Capacity Rating Point.

INPUT POWER INCLUDES THE CONDENSER AND COMPRESSOR MOTORS BUT NOT THE INDOOR BLOWER MOTOR



**TABLE 19: 20 TON CAPACITY TABLE - 105° & 115°F**

20 Ton Capacity Tables										
HB240 & LB240										
AIR ON EVAPORATOR				OUTDOOR AMBIENT TEMPERATURE (F): <b>105°</b>						
CFM	W.B.	GROSS	INPUT	GROSS SENSIBLE CAPACITY (MBh)						
	TEMP	CAP.	POWER	(RETURN AIR DRY BULB TEMP.- (F))						
	(F)	(MBh)	(kW)	86	83	80	77	74	71	68
6000	72	245.6	25.60	148.7	131.6	114.5	97.4	80.2	#N/A	#N/A
	67	228.4	25.00	184.5	167.4	150.3	133.2	116.1	99.0	81.9
	62	211.9	24.47	211.9	198.0	180.9	163.7	146.6	129.5	112.4
	57	210.8	24.50	210.8	204.7	187.6	170.5	153.4	136.3	119.2
7000	72									
	67	253.0	25.77	164.4	144.2	124.0	103.7	83.5	#N/A	#N/A
	62	235.2	25.16	203.2	183.0	162.8	142.5	122.3	102.1	81.9
	57	218.3	24.63	218.3	211.3	195.9	175.7	155.4	135.2	115.0
8000	72	217.1	24.66	217.1	214.1	203.2	183.0	162.8	142.5	122.3
	67									
	62	260.4	25.94	180.1	156.8	133.5	110.1	86.8	#N/A	#N/A
	57	242.1	25.32	221.9	198.6	175.2	151.9	128.6	105.3	81.9
8600	72	224.7	24.79	224.7	224.7	210.9	187.6	164.2	140.9	117.6
	67	223.4	24.82	223.4	223.4	218.8	195.4	172.1	148.8	125.5
	62									
	57	261.9	26.04	188.1	162.7	137.3	112.0	86.6	#N/A	#N/A
9200	72	243.5	25.43	230.7	205.7	180.3	154.9	129.6	104.2	78.8
	67	226.0	24.89	226.0	226.0	217.0	191.6	166.2	140.9	115.5
	62	224.8	24.92	224.8	224.8	222.4	197.1	171.7	146.3	120.9
	57									

Indicates Nominal Capacity Rating Point.

INPUT POWER INCLUDES THE CONDENSER AND COMPRESSOR MOTORS BUT NOT THE INDOOR BLOWER MOTOR

20 Ton Capacity Tables										
HB240 & LB240										
AIR ON EVAPORATOR				OUTDOOR AMBIENT TEMPERATURE (F): <b>115°</b>						
CFM	W.B.	GROSS	INPUT	GROSS SENSIBLE CAPACITY (MBh)						
	TEMP	CAP.	POWER	(RETURN AIR DRY BULB TEMP.- (F))						
	(F)	(MBh)	(kW)	86	83	80	77	74	71	68
6000	72	237.4	28.09	146.1	129.0	111.9	94.8	77.7	#N/A	#N/A
	67	219.5	27.31	180.8	163.7	146.6	129.5	112.4	95.3	78.2
	62	205.4	26.78	205.4	193.2	176.1	159.0	141.9	124.8	107.7
	57	207.1	26.89	207.1	199.0	181.9	164.8	147.7	130.6	113.4
7000	72	243.1	28.23	161.3	141.1	120.9	100.7	80.4	#N/A	#N/A
	67	224.8	27.45	198.9	178.6	158.4	138.2	118.0	97.8	77.5
	62	210.3	26.91	210.3	204.2	190.3	170.0	149.8	129.6	109.4
	57	212.0	27.02	212.0	208.0	196.5	176.3	156.1	135.8	115.6
8000	72	248.8	28.37	176.5	153.2	129.9	106.5	83.2	#N/A	#N/A
	67	230.0	27.58	216.9	193.5	170.2	146.9	123.6	100.2	76.9
	62	215.2	27.04	215.2	215.2	204.4	181.1	157.8	134.4	111.1
	57	217.0	27.15	217.0	217.0	211.1	187.8	164.5	141.1	117.8
8600	72	254.0	28.49	186.7	161.3	136.0	110.6	85.2	#N/A	#N/A
	67	234.8	27.70	228.2	203.6	178.2	152.8	127.4	102.1	76.7
	62	219.7	27.15	219.7	219.7	214.0	188.6	163.3	137.9	112.5
	57	221.5	27.26	221.5	221.5	218.6	193.2	167.8	142.4	117.1
9200	72	259.2	28.61	196.9	169.5	142.0	114.6	87.2	#N/A	#N/A
	67	239.6	27.81	239.6	213.6	186.2	158.7	131.3	103.9	76.5
	62	224.1	27.26	224.1	224.1	223.6	196.2	168.7	141.3	113.9
	57	226.0	27.38	226.0	226.0	226.0	198.6	171.2	143.8	116.3

Indicates Nominal Capacity Rating Point.

INPUT POWER INCLUDES THE CONDENSER AND COMPRESSOR MOTORS BUT NOT THE INDOOR BLOWER MOTOR

**TABLE 20: 20 TON CAPACITY TABLE - 125°F**

20 Ton Capacity Tables										
HB240 & LB240										
AIR ON EVAPORATOR				OUTDOOR AMBIENT TEMPERATURE (F): 125°						
CFM	W.B. TEMP (F)	GROSS CAP. (MBh)	INPUT POWER (kW)	GROSS SENSIBLE CAPACITY (MBh) (RETURN AIR DRY BULB TEMP.- (F))						
				86	83	80	77	74	71	68
6000	72	229.3	30.6	143.5	126.4	109.3	92.2	75.1	#N/A	#N/A
	67	210.7	29.6	177.2	160.1	143.0	125.9	108.8	91.6	74.5
	62	198.8	29.1	198.8	188.5	171.3	154.2	137.1	120.0	102.9
	57	203.4	29.3	203.4	193.2	176.1	159.0	141.9	124.8	107.7
7000	72	233.3	30.7	158.2	138.0	117.8	97.6	77.3	#N/A	#N/A
	67	214.3	29.7	194.5	174.3	154.1	133.9	113.6	93.4	73.2
	62	202.2	29.2	202.2	197.1	184.7	164.4	144.2	124.0	103.8
	57	207.0	29.4	207.0	201.9	189.8	169.6	149.4	129.2	108.9
8000	72	237.2	30.8	172.9	149.6	126.3	102.9	79.6	#N/A	#N/A
	67	217.9	29.8	211.8	188.5	165.2	141.8	118.5	95.2	71.9
	62	205.7	29.3	205.7	205.7	198.0	174.6	151.3	128.0	104.6
	57	210.5	29.5	210.5	210.5	203.5	180.1	156.8	133.5	110.2
8600	72	246.1	30.9	185.3	160.0	134.6	109.2	83.8	#N/A	#N/A
	67	226.1	30.0	225.7	201.4	176.1	150.7	125.3	99.9	74.6
	62	213.3	29.4	213.3	213.3	211.0	185.6	160.3	134.9	109.5
	57	218.2	29.6	218.2	218.2	214.7	189.3	164.0	138.6	113.2
9200	72	255.0	31.1	197.7	170.3	142.9	115.5	88.0	#N/A	#N/A
	67	234.3	30.1	234.3	214.4	186.9	159.5	132.1	104.7	77.2
	62	221.0	29.5	221.0	221.0	221.0	196.7	169.2	141.8	114.4
	57	226.0	29.7	226.0	226.0	226.0	198.5	171.1	143.7	116.3

Indicates Nominal Capacity Rating Point.

INPUT POWER INCLUDES THE CONDENSER AND COMPRESSOR MOTORS BUT NOT THE INDOOR BLOWER MOTOR

**TABLE 21: LB180 15 TON AIRFLOW TABLE**

CFM	0.4 ESP			0.6 ESP			0.8 ESP			1 ESP			1.2 ESP			1.4 ESP		
	RPM	BHP	kW	RPM	BHP	kW	RPM	BHP	kW	RPM	BHP	kW	RPM	BHP	kW	RPM	BHP	kW
4400				660	1.5	1.43	725	1.8	1.69	756	2.0	1.86	886	2.4	2.29	928	2.6	2.4
4600				663	1.6	1.46	733	1.9	1.77	775	2.1	1.99	891	2.6	2.4	937	2.8	2.59
4800				667	1.6	1.5	741	2.0	1.85	794	2.3	2.12	897	2.7	2.52	946	3.0	2.78
5000				671	1.7	1.55	749	2.1	1.94	811	2.4	2.26	903	2.8	2.64	955	3.2	2.98
5200				676	1.7	1.61	758	2.2	2.03	828	2.6	2.39	910	3.0	2.77	963	3.4	3.17
5400				682	1.8	1.68	767	2.3	2.13	844	2.7	2.54	917	3.1	2.91	972	3.6	3.36
5600				688	1.9	1.76	776	2.4	2.24	859	2.9	2.68	924	3.3	3.05	981	3.8	3.56
5800				696	2.0	1.85	785	2.5	2.36	873	3.0	2.83	931	3.4	3.2	990	4.0	3.75
6000	647	1.9	1.78	704	2.1	1.95	794	2.7	2.48	885	3.2	2.98	938	3.6	3.36	998	4.2	3.94
6200	654	2.0	1.83	712	2.2	2.06	804	2.8	2.61	897	3.4	3.14	946	3.8	3.53	1007	4.4	4.14
6400	662	2.0	1.89	722	2.3	2.18	814	2.9	2.74	909	3.5	3.29	954	4.0	3.7			
6600	670	2.1	1.97	732	2.5	2.31	824	3.1	2.89	919	3.7	3.45	963	4.1	3.88			
6800	679	2.2	2.06	742	2.6	2.45	834	3.2	3.03	928	3.9	3.62	971	4.4	4.07			
7000	688	2.3	2.17	754	2.8	2.6	844	3.4	3.19	936	4.1	3.79	980	4.6	4.27			
7200	698	2.5	2.3	766	3.0	2.77	855	3.6	3.35	944	4.2	3.96	990	4.8	4.47			
7400	708	2.6	2.45	779	3.1	2.94	866	3.8	3.52	950	4.4	4.13	999	5.0	4.68			
7600	719	2.8	2.61	792	3.3	3.12	877	4.0	3.7	956	4.6	4.31						
7800	730	3.0	2.78	807	3.5	3.31	888	4.1	3.88	960	4.8	4.49						

Denotes use of 5 hp motor with high static pulley kit.

Note: Airflow tables based on 2" filters, dry evaporator coil

**TABLE 22: LB240 20 TON AIRFLOW TABLE**

CFM	0.4 ESP			0.6 ESP			0.8 ESP			1 ESP			1.2 ESP			1.4 ESP		
	RPM	BHP	kW	RPM	BHP	kW	RPM	BHP	kW	RPM	BHP	kW	RPM	BHP	kW	RPM	BHP	kW
6000							612	2.0	1.77	681	2.5	2.24	720	2.7	2.44	763	3.1	2.71
6200							617	2.1	1.87	684	2.6	2.32	724	2.9	2.53	767	3.2	2.82
6400							623	2.2	1.97	688	2.7	2.40	727	3.0	2.63	771	3.3	2.94
6600							629	2.3	2.07	692	2.8	2.48	731	3.1	2.73	776	3.4	3.06
6800							634	2.4	2.17	695	2.9	2.57	735	3.2	2.83	781	3.6	3.19
7000							640	2.6	2.27	699	3.0	2.66	739	3.3	2.94	786	3.7	3.32
7200							646	2.7	2.38	703	3.1	2.75	744	3.4	3.05	791	3.9	3.46
7400				582	2.0	1.74	651	2.8	2.48	707	3.2	2.85	748	3.6	3.16	797	4.1	3.61
7600				590	2.1	1.87	657	2.9	2.59	711	3.3	2.95	753	3.7	3.28	803	4.2	3.76
7800				597	2.3	2.00	662	3.0	2.69	715	3.4	3.05	757	3.8	3.40	809	4.4	3.92
8000				603	2.4	2.13	667	3.2	2.80	719	3.6	3.16	762	4.0	3.52	816	4.6	4.08
8200				610	2.5	2.26	673	3.3	2.91	723	3.7	3.26	767	4.1	3.65			
8400				617	2.7	2.40	678	3.4	3.02	727	3.8	3.38	772	4.3	3.79			
8600				624	2.8	2.53	683	3.5	3.13	731	3.9	3.49	777	4.4	3.92			
8800				630	3.0	2.66	689	3.6	3.24	735	4.1	3.61	783	4.6	4.06			
9000				637	3.1	2.79	694	3.8	3.35	740	4.2	3.73	788	4.7	4.21			
9200	577	2.0	1.80	643	3.3	2.92	699	3.9	3.46	744	4.3	3.85	794	4.9	4.36			
9400	584	2.3	2.08	649	3.4	3.06	704	4.0	3.57	748	4.5	3.98	800	5.1	4.51			
9600	591	2.6	2.34	655	3.6	3.19	709	4.1	3.68	753	4.6	4.11	806	5.3	4.67			
9800	598	2.9	2.59	661	3.7	3.32	714	4.3	3.80	757	4.8	4.25	812	5.4	4.83			
10000	605	3.2	2.81	667	3.9	3.46	719	4.4	3.91									

Denotes use of high static pulley option.

Note: Airflow tables based on 2" filters, dry evaporator coil

### 15 TON BLOWER PERFORMANCE

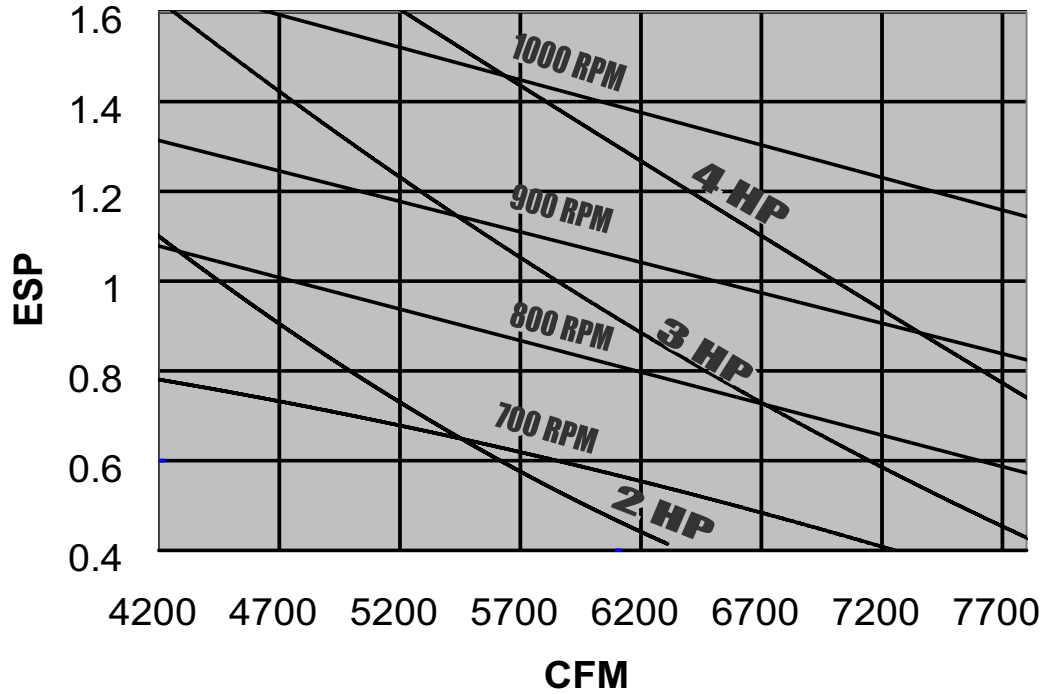

FIGURE 8 - 15 TON BLOWER PERFORMANCE

### 20 TON BLOWER PERFORMANCE

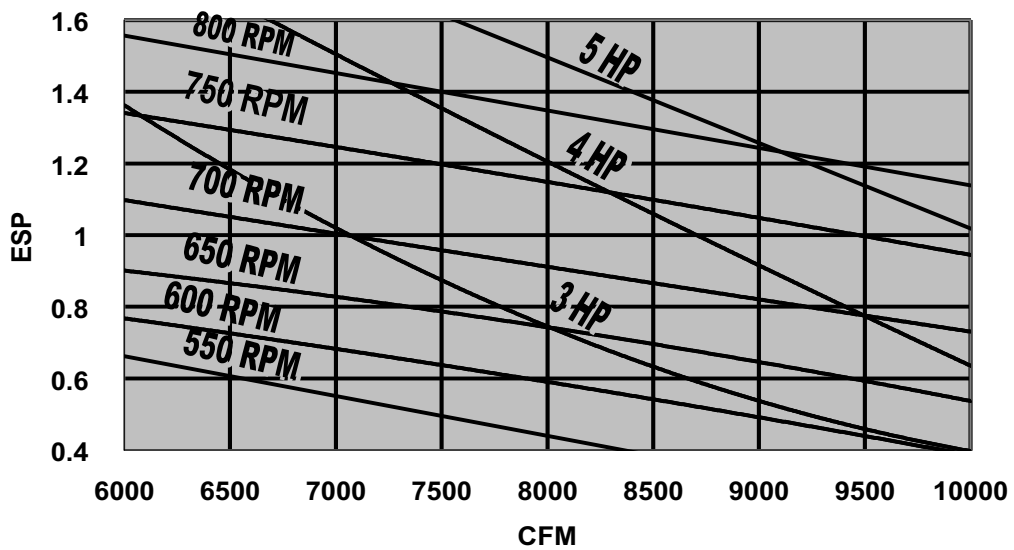

FIGURE 9 - 20 TON BLOWER PERFORMANCE

**TABLE 23: BLOWER DRIVE DATA**

Unit Model	Drive Data							
	Model Number	Blower RPM Range	Adj. Motor Pulley		Fixed Blower pulley		Belts	
			Datum Dia. (In.)	Bore (In.)	Datum Dia. (In.)	Bore (In.)	Qty.	Designation
LB180	1LD0436	640-810	4.0-5.0	7/8	11	1-3/16	1	A57
	1LD0437	800-1000	5.3-6.3	1-1/8	11	1-3/16	2	A55
LB240	1LD0438	580-720	4.0-5.0	1-1/8	12	1-3/16	2	A63
	1LD0439	700-830	4.0-5.0	1-1/8	13	1-3/16	2	A68

**TABLE 24: BLOWER DATA**

Unit Model	Blower Motor Data <sup>1</sup>				Drive Data	
	HP	Model Number	Frame size	Voltage (3PH-60Hz.)	Model Number	Blower RPM Range
LB180	3	2LR04603033	56	208/230/460 <sup>1</sup>	1LD0436	640-810
		2LR04603058	56	575	1LD0436	640-810
	5	2LR04605023	184	208	1LD0437	800-1000
		2LR04605032	184	230/460	1LD0437	800-1000
		2LP04605058	184	575	1LD0437	800-1000
LB240	5	2LR04605023	184	208	1LD0438	580-720
					1LD0439	700-830
	2LR04605032	184	208/230/460	1LD0438	580-720	
				1LD0439	700-830	
	2LP04605058	184	575	1LD0437	800-1000	
				1LD0439	700-830	

1. Three-phase motors will always be wired for 460 volt power supply. Refer to the wiring diagram inside the motor terminal box.

**TABLE 25: INDOOR ELECTRICAL RATINGS**

Model Number	Blower Motor HP	Power Supply	FLA	Minimum Circuit Ampacity	Max. Fuse Size <sup>1</sup>
LB180	3	208-3-60	10.6	13.3	20
		230-3-60	9.6	12.0	20
	5	208-3-60	17.5	21.9	35
		230-3-60	16.7	20.9	35
	3	460-3-60	4.8	6.0	15
		575-3-60	3.6	4.5	15
5	460-3-60	7.6	9.5	15	
	575-3-60	5.2	6.5	15	
LB240	5	208-3-60	17.5	21.9	35
		230-3-60	16.7	20.9	35
		460-3-60	7.6	9.5	15
		575-3-60	5.2	6.5	15

1. Maximum fuse or maximum circuit breaker (HACR type per NEC).

**TABLE 26: INDOOR UNIT WEIGHTS AND CORNER WEIGHTS**

Unit Size	Position	Shipping Weight	Operating	A	B	C	D	Unit Length	Unit Width
15 Ton Indoor	Horizontal	720	830	178	216	239	197	89.5	59
15 Ton Indoor	Vertical	720	830	198	224	217	191	89.5	29.5
20 Ton Indoor	Horizontal	990	1115	212	195	340	368	100	74
20 Ton Indoor	Vertical	990	1115	281	254	276	305	100	36.5

NOTE: All dimensions in inches.

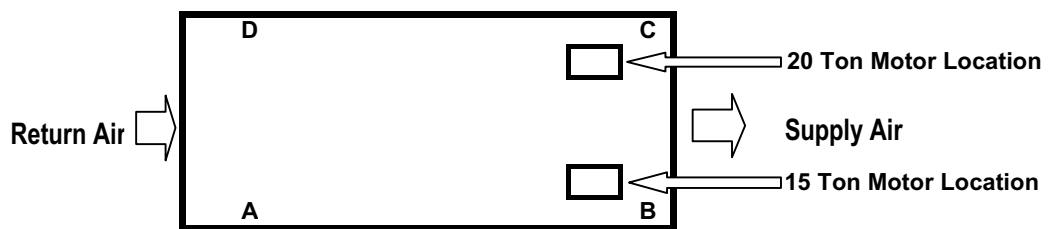

**Horizontal Application Corner Weights**

**FIGURE 10 - HORIZONTAL APPLICATION CORNER WEIGHTS**

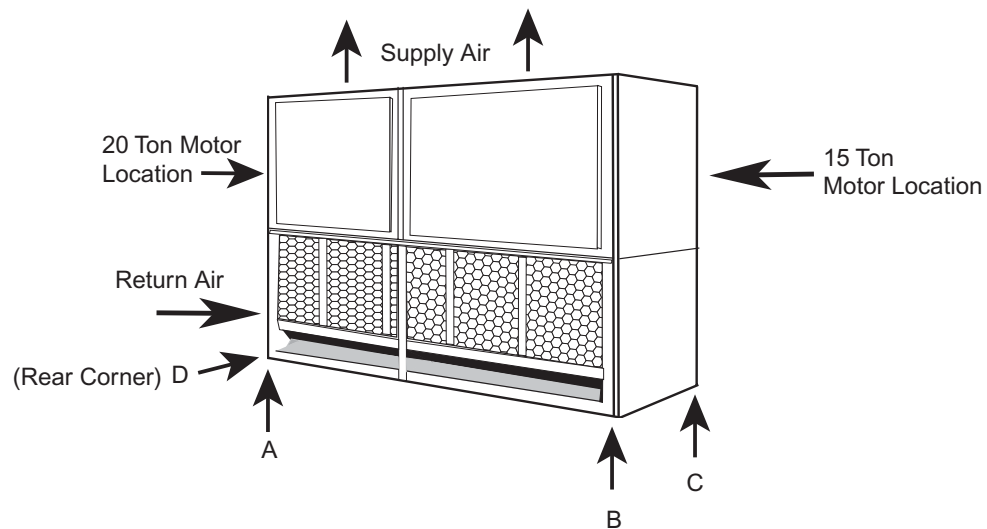

**FIGURE 11 - VERTICAL APPLICATION CORNER WEIGHTS**

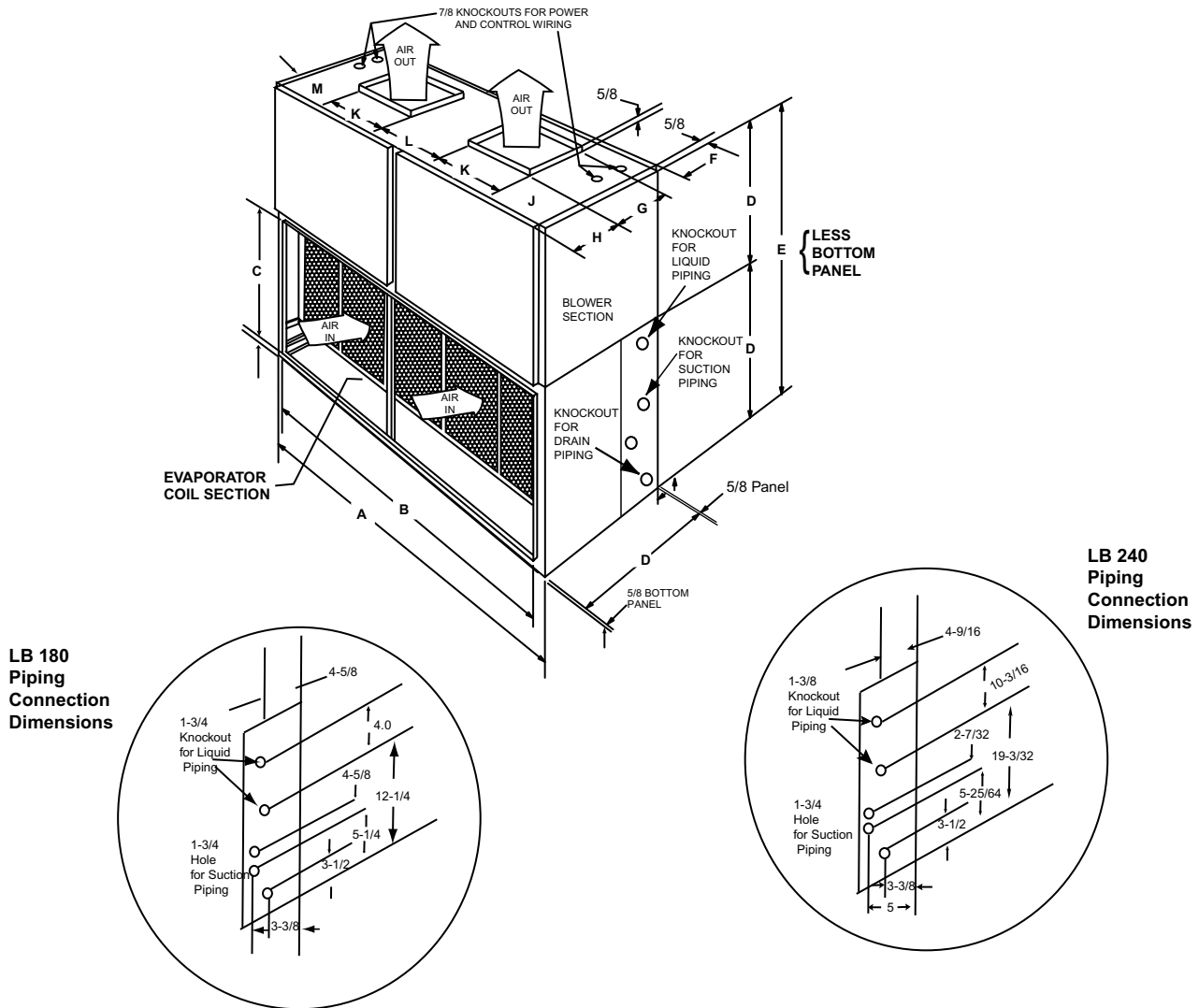
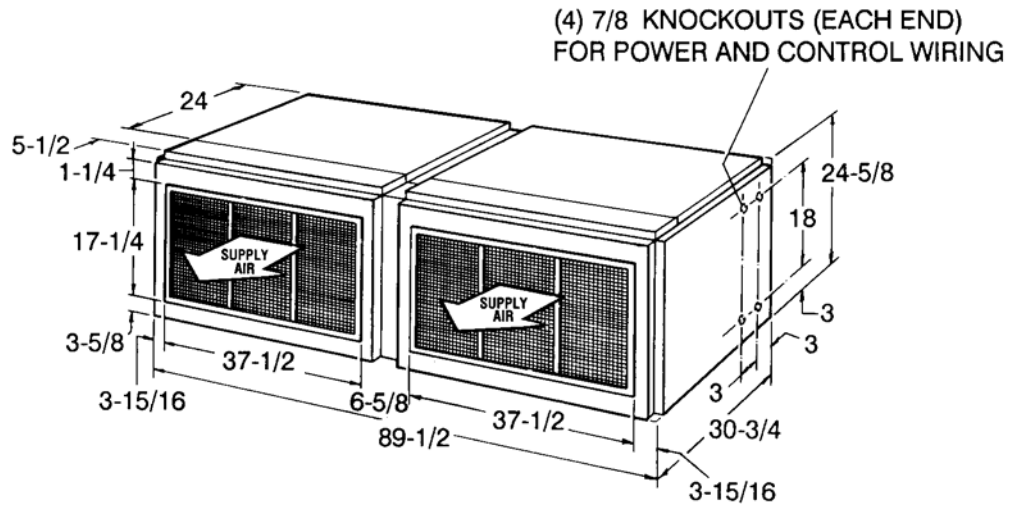

FIGURE 12 - UNIT DIMENSIONS LB180 AND LB240

TABLE 27: UNIT DIMENSIONS LB180 AND LB240

MODEL	A	B	C	D	E	F	G	H	J	K	L	M
LB180	89-1/2	85.0	26.0	29-1/2	59	1-7/16	15-7/8	12-7/16	15-13/16	16	16	20-3/4
LB240	100-1/8	95-5/8	33-1/4	36-5/8	73-1/4	2-1/2	18-7/8	16-1/2	15-13/16	21-7/8	18	22-9/16



**FIGURE 13 - LB180 SUPPLY AIR PLENUM DIMENSIONS<sup>1</sup>**

1. Shipped knocked down for field assembly

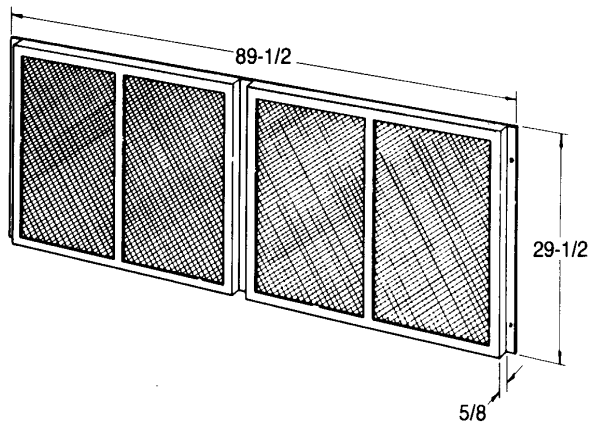

**FIGURE 14 - RETURN AIR GRILLE FOR LB180 DIMENSIONS**

## GUIDE SPECIFICATIONS

### EVAPORATOR - LA300, LB180, 240, 360, 480 & 600

#### EACH UNIT SHALL BE:

- covered by a 1-year limited parts warranty on the complete unit.
- In current production with published literature available to check performance, limitations, specifications, power requirements, dimensions, operation and appearance, and equipped with a V-belt drive option that will permit the blower RPM to be adjusted to meet the exact CFM requirement of the system.

#### EACH UNIT SHALL HAVE:

- a steel angle frame to provide the rigid support required for shipping, rigging and years of dependable operation;
- exterior panels of 18 gauge steel, finished with baked enamel to provide a long-lasting quality appearance;
- removable panels to provide easy access to the internal components for maintenance and service; and,
- A filter rack with 2" filters

#### THE DIMENSIONS OF EACH UNIT SHALL NOT EXCEED THOSE SPECIFIED.

#### THE BLOWER MOTOR SHALL:

- be mounted within the insulated cabinet to minimize the transmission of sound to the surrounding space, and
- Have a service factor of 1.15.

#### THE EVAPORATOR COIL SHALL:

- Consist of copper tubes arranged in staggered rows, mechanically expanded into aluminum fins, be draw-through, and
- include factory-mounted distributors, expansion valves and solenoid valves for both capacity reduction and pump down.

#### THE BLOWER WHEELS SHALL BE:

Dynamically balanced to minimize the levels of sound and vibration generated by the unit.

### CONDENSER - LA300, LB180, 240, 360, 480 & 600

#### EACH UNIT SHALL BE:

- ETL and cETL approved.
- completely assembled for one-piece shipping and rigging.
- leak pressure and functionally tested at the factory to assure a trouble-free start-up after installation.

- covered by a 1-year limited parts warranty on the complete unit.

#### EACH UNIT SHALL HAVE:

- a steel angle frame to provide the rigid support required for shipping, rigging and years of dependable operation.
- zinc-coated steel that has been finished by a powder paint process to provide a long-lasting, quality appearance.
- removable panels for easy access to all internal components during maintenance and service.

#### THE DIMENSIONS OF EACH UNIT SHALL NOT EXCEED THOSE SPECIFIED IN THE PLANS.

#### EACH COMPRESSOR SHALL BE:

- mounted on isolators to minimize the transmission of vibration.

#### ALL CONDENSER COILS SHALL BE:

- draw thru design.
- constructed of copper tubes arranged in staggered rows and mechanically expanded into aluminum fins.

#### THE CONDENSER FAN MOTOR(S) SHALL:

- be directly connected to the condenser fans.
- have permanently lubricated ball bearings.
- have inherent overload protection.
- be three phase.
- be arranged for vertical discharge of the condenser air.

#### THE WIRING FOR EACH UNIT SHALL INCLUDE:

- a crankcase heater (one per compressor).
- all 24-volt temperature control circuit.
- both high and low pressure cutouts.
- Solid-state or internal line break compressor motor protection.
- Condenser fan motor control to assure stable operation at ambient temperature down to 40 °F.

#### THE REFRIGERANT PIPING OF EACH SYSTEM SHALL INCLUDE:

- a filter-drier shipped separately for field installation.
- a liquid line, moisture-indicating, sight glass shipped separately for field installation.
- liquid line and suction line valve shipped separately for field installation.

Subject to change without notice. Printed in U.S.A.  
Copyright © 2008 by Unitary Products Group. All rights reserved.

036-21323-002-C-0206  
Supersedes: 036-21323-002-B-0804