

INSTALLATION MANUAL

R-22/R-407C OUTDOOR SPLIT-SYSTEM AIR CONDITIONING

MODELS: GCGA SERIES

1.5 TO 6.3 TONS – 1 & 3 PHASE



LIST OF SECTIONS

GENERAL	1	EVACUATION	5
SAFETY	1	SYSTEM CHARGE	5
UNIT INSTALLATION	2	ELECTRICAL CONNECTIONS	7
ORIFICE INSTALLATION	5	INSTRUCTING THE OWNER	12
TXV INSTALLATION	5	WIRING DIAGRAM	13

LIST OF FIGURES

Typical Installation	2	Typical Field Wiring (Air Handler / Electrical Heat) (Three Phase - GCGA36-60)	9
Installation of Vapor Line	3	Typical Field Wiring for 76 Models with Air Handler (Three-Phase - GCGA76)	9
Underground Installation	3	Thermostat Chart - Single Stage AC with PSC Furnace	10
Heat Protection	4	Thermostat Chart - Single Stage AC with PSC Air Handler	11
Orifice Installation	5	Wiring Diagram - Single Phase	13
Outdoor Unit Control Box (Single Phase)	8	Wiring Diagram - Three Phase - GCGA36-60	14
Outdoor Unit Control Box (Three Phase - GCGA36-60)	8	Wiring Diagram - Three Phase - GCGA76	15
Outdoor Unit Control Box (GCGA76 With Transformer)	8		
Typical Field Wiring (Air Handler / Electrical Heat) (Single-Phase)	9		

LIST OF TABLES

Application Limitations	2	R-407C Saturation Properties (Superheat Only)	7
R-22 Saturation Properties	6	R-407C Saturation Properties (Subcooling Only)	7

SECTION I: GENERAL

The outdoor units are designed to be connected to a matching indoor coil with sweat connect lines. Since these units are designed to operate on either R-22 or R-407C, they have been shipped from the factory with a nitrogen holding charge.

CAUTION

This unit does not contain any refrigerant. It contains a nitrogen holding charge. Operating this unit with the nitrogen holding charge will damage the compressor.

IMPORTANT

Before operating this unit, vent the nitrogen and evacuate the entire system below 500 microns. Weigh in the refrigerant using the Tabular Data Sheet and Installation Manual.

The refrigerant charge may need to be changed for some indoor-outdoor unit combinations, elevation differences or total line lengths. Refer to Application Data covering "General Piping Recommendations and Refrigerant Line Length" (Part Number 247077).

SECTION II: SAFETY



This is a safety alert symbol. When you see this symbol on labels or in manuals, be alert to the potential for personal injury.

Understand and pay particular attention to the signal words **DANGER**, **WARNING**, or **CAUTION**.

DANGER indicates an **imminently** hazardous situation, which, if not avoided, **will result in death or serious injury**.

WARNING indicates a **potentially** hazardous situation, which, if not avoided, **could result in death or serious injury**.

CAUTION indicates a potentially hazardous situation, which, if not avoided **may result in minor or moderate injury**. It is also used to alert against unsafe practices and hazards involving only property damage.

CAUTION

This product must be installed in strict compliance with the enclosed installation instructions and any applicable local, state, and national codes including, but not limited to building, electrical, and mechanical codes.

WARNING

Improper installation may create a condition where the operation of the product could cause personal injury or property damage. Improper installation, adjustment, alteration, service or maintenance can cause injury or property damage. Refer to this manual for assistance or for additional information, consult a qualified contractor, installer or service agency.

INSPECTION

As soon as a unit is received, it should be inspected for possible damage during transit. If damage is evident, the extent of the damage should be noted on the carrier's delivery receipt. A separate request for inspection by the carrier's agent should be made in writing. See Local Distributor for more information.

Special Requirements For Installing/Serviceing R-407C Equipment

- Gauge sets, hoses, refrigerant containers, and recovery system must be designed to handle the POE/PVE type oils, and the higher pressures of R-407C.
- Manifold sets should be high side and low side with low side retard.
- All hoses must have a 700 psig service pressure rating.
- Leak detectors should be designed to detect HFC refrigerant.
- Recovery equipment (including refrigerant recovery containers) must be specifically designed to handle R-407C.
- A liquid-line filter drier is required on every unit.

LIMITATIONS

The unit should be installed in accordance with all National, State and Local Safety Codes and the limitations listed below:

1. Limitations for the indoor unit, coil, and appropriate accessories must also be observed.
2. The outdoor unit must not be installed with any duct work in the air stream. The outdoor fan is the propeller type and is not designed to operate against any additional external static pressure.
3. The maximum and minimum conditions for operation must be observed to ensure a system that will give maximum performance with minimum service.

TABLE 1: Application Limitations

Ambient Air Temperature on Outdoor Coil		Air Temperature on Indoor Coil	
Min. DB	Max. DB	Min. WB	Max. WB
50°F	125°F	57°F	72°F

4. The unit should not be operated at outdoor temperatures below 50°F without an approved low ambient operation accessory kit installed.
5. The maximum allowable line length for this product is 75 feet.

SECTION III: UNIT INSTALLATION

LOCATION

Before starting the installation, select and check the suitability of the location for both the indoor and outdoor unit. Observe all limitations and clearance requirements.

The outdoor unit must have sufficient clearance for air entrance to the condenser coil, air discharge, and service access. See Figure 1.

NOTICE

For multiple unit installations, units must be spaced a minimum of 24" (61 cm) apart (coil face to coil face).

If the unit is to be installed on a hot sun exposed roof or a black-topped ground area, the unit should be raised sufficiently above the roof or ground to avoid taking the accumulated layer of hot air into the outdoor unit.

Provide an adequate structural support.

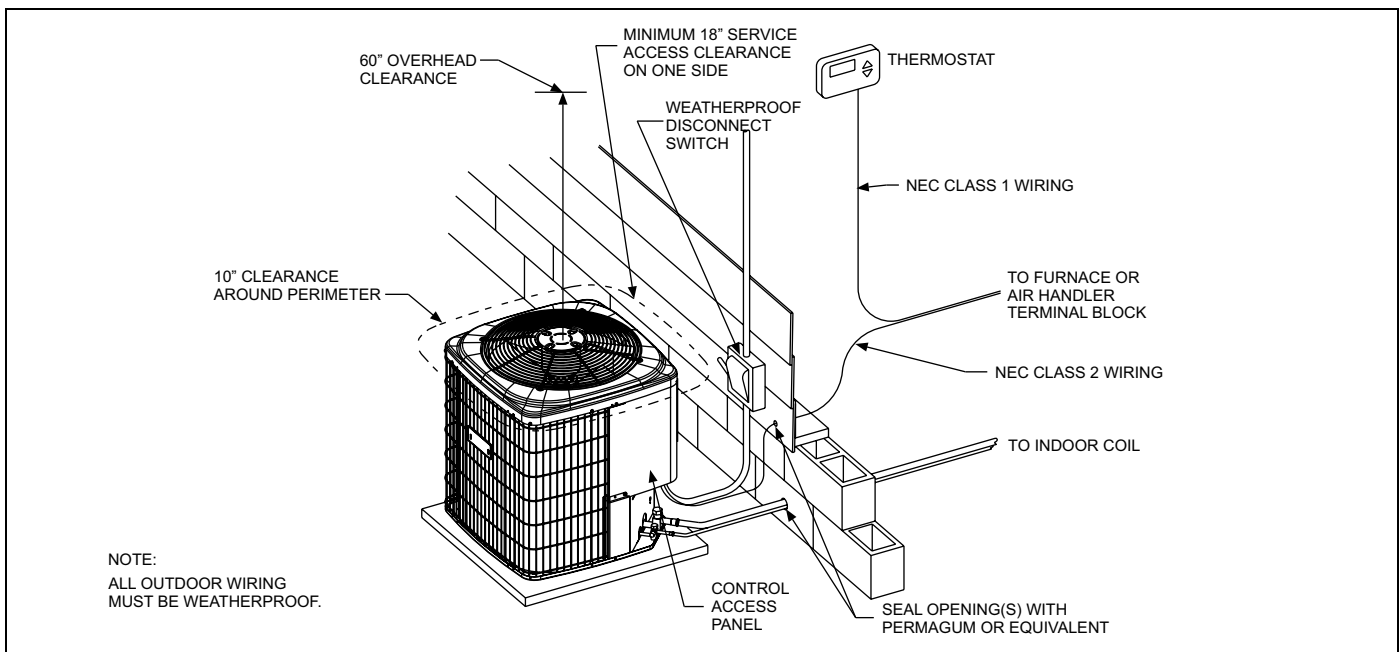

FIGURE 1: Typical Installation

GROUND INSTALLATION

The unit should be installed on a solid base that is 2" (5.1 cm) above grade and will not shift or settle, causing strain on the refrigerant lines and possible leaks. Maintain the clearances shown in Figure 1 and install the unit in a level position. The base pad should not come in contact with the foundation or side of the structure because sound may be transmitted to the residence.

The length of the refrigerant tubing between the outdoor unit and indoor coil should be as short as possible to avoid capacity and efficiency losses. Excessive spacing of the outdoor unit from the home can result in the refrigerant lines being restricted by trampling or being punctured by lawn mowers. Locate the outdoor unit away from bedroom windows or other rooms where sound might be objectionable.

Adverse effects of snow or sleet accumulating on the outdoor coil can be eliminated by placing the outdoor unit where the prevailing wind does not blow across the unit. Trees, shrubs, corners of buildings, and fences standing off from the coil can reduce capacity loss due to wind chill effect.

Provide ample clearance from shrubs to allow adequate air to pass across the outdoor coil without leaves or branches being pulled into the coil.

ROOF INSTALLATION

When installing units on a roof, the structure must be capable of supporting the total weight of the unit, including a pad, lintels, rails, etc., which should be used to minimize the transmission of sound or vibration into the conditioned space.

LIQUID LINE FILTER-DRYER

The air conditioning unit's filter/dryer is located on the liquid line.

NOTICE

Replacements for the liquid line drier must be exactly the same as marked on the original factory drier. See Source1 for O.E.M. replacement driers.

CAUTION

Failure to do so or using a substitute drier or a granular type may result in damage to the equipment.

Filter-Drier Source 1 Part No.	Apply with Models
S1-0292215600	18, 24, 30, 36
S1-0292215700	48, 60
S1-0261477012	76

PIPING CONNECTIONS

The outdoor condensing unit must be connected to the indoor evaporator coil using field supplied refrigerant grade (ACR) copper tubing that is internally clean and dry. Units should be installed only with the tubing sizes for approved system combinations as specified in tabular data sheet. The initial charge given is applicable for total tubing lengths up to 15 feet (4.6 m). See Application Data Part Number 247077 for installing tubing of longer lengths and elevation differences.

NOTICE

Using a larger than specified line size could result in oil return problems. Using too small a line will result in loss of capacity and other problems caused by insufficient refrigerant flow. Slope horizontal vapor lines at least 1" (2.5 cm) every 20 feet (6.1 m) toward the outdoor unit to facilitate proper oil return.

PRECAUTIONS DURING LINE INSTALLATION

1. Install the lines with as few bends as possible. Care must be taken not to damage the couplings or kink the tubing. Use clean hard drawn copper tubing where no appreciable amount of bending around obstruction is necessary. If soft copper must be used, care must be taken to avoid sharp bends which may cause a restriction.
2. The lines should be installed so that they will not obstruct service access to the coil, air handling system, or filter.
3. Care must also be taken to isolate the refrigerant lines to minimize noise transmission from the equipment to the structure.
4. The vapor line must be insulated with a minimum of 1/2" foam rubber insulation (Armaflex or equivalent). Liquid lines that will be exposed to direct sunlight, high temperatures, or excessive humidity must also be insulated.
5. Tape and suspend the refrigerant lines as shown. DO NOT allow tube metal-to-metal contact. See Figure 2.
6. Use PVC piping as a conduit for all underground installations as shown in Figure 3. Buried lines should be kept as short as possible to minimize the build up of liquid refrigerant in the vapor line during long periods of shutdown.
7. Pack fiberglass insulation and a sealing material such as perma-gum around refrigerant lines where they penetrate a wall to reduce vibration and to retain some flexibility.
8. For systems with total line length exceeding 70 feet (21.3 m), see APPLICATION DATA and worksheet "General Piping Recommendations and Refrigerant Line Length" for vapor and liquid line sizing, calibration of liquid line pressure loss or gain, determination of vapor line velocity, elevation limitations, orifice connections, system charging, traps, etc.

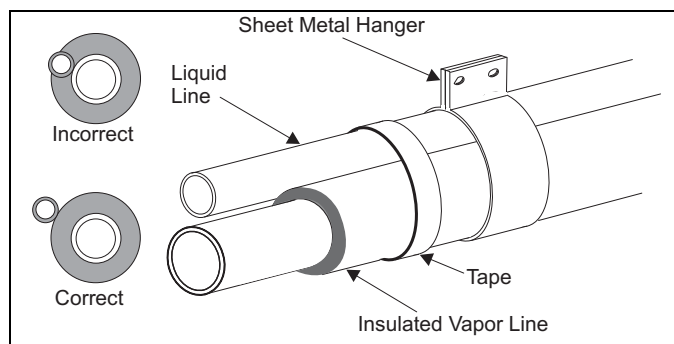

FIGURE 2: Installation of Vapor Line

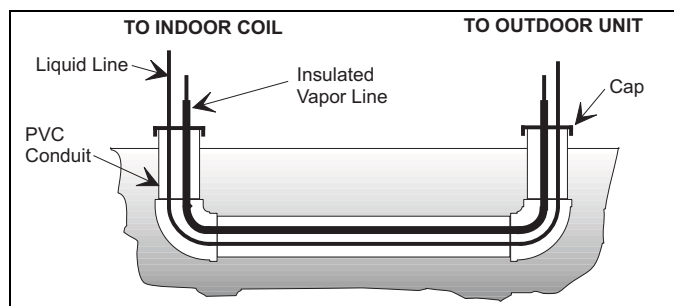

FIGURE 3: Underground Installation

PRECAUTIONS DURING BRAZING OF LINES

All outdoor unit and evaporator coil connections are copper-to-copper and should be brazed with a phosphorous-copper alloy material such as Silfos-5 or equivalent. DO NOT use soft solder. The outdoor units have reusable service valves on both the liquid and vapor connections. Since these units are designed to operate on either R-22 or R-407C, they have been shipped from the factory with a nitrogen holding charge. Refer to the Tabular Data sheets for refrigerant charge quantities. The reusable service valves are provided to evacuate and charge per this instruction.

Serious service problems can be avoided by taking adequate precautions to assure an internally clean and dry system.

CAUTION

Dry nitrogen should always be supplied through the tubing while it is being brazed, because the temperature required is high enough to cause oxidation of the copper unless an inert atmosphere is provided. The flow of dry nitrogen should continue until the joint has cooled. Always use a pressure regulator and safety valve to insure that only low pressure dry nitrogen is introduced into the tubing. Only a small flow is necessary to displace air and prevent oxidation.

PRECAUTIONS DURING BRAZING SERVICE VALVE

Precautions should be taken to prevent heat damage to service valve by wrapping a wet rag around it as shown in Figure 4. Also, protect all painted surfaces, insulation, and plastic base during brazing. After brazing, cool joint with wet rag.

WARNING

This is not a backseating valve. The service access port has a valve core. Opening or closing valve does not close service access port.

If the valve stem is backed out past the chamfered retaining wall, the O-ring can be damaged causing leakage or system pressure could force the valve stem out of the valve body possibly causing personal injury.

Connect the refrigerant lines using the following procedure:

1. Remove the cap and Schrader core from both the liquid and vapor service valve service ports at the outdoor unit. Connect low pressure nitrogen to the liquid line service port.
2. Braze the liquid line to the liquid valve at the outdoor unit. Be sure to wrap the valve body with a wet rag. Allow the nitrogen to continue flowing.
3. Carefully remove the plugs from the evaporator liquid and vapor connections at the indoor coil.

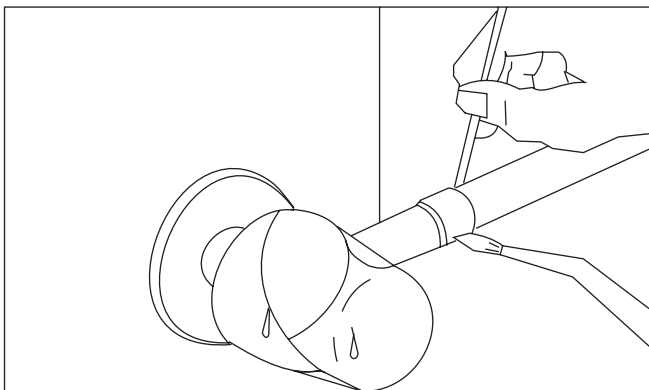

FIGURE 4: Heat Protection

CAUTION

Do not install any coil in a furnace which is to be operated during the heating season without attaching the refrigerant lines to the coil. The coil is under 30 to 35 psig inert gas pressure which must be released to prevent excessive pressure build-up and possible coil damage.

4. Braze the liquid line to the evaporator liquid connection. Nitrogen should be flowing through the evaporator coil.
5. Slide the grommet away from the vapor connection at the indoor coil. Braze the vapor line to the evaporator vapor connection. After the connection has cooled, slide the grommet back into original position.
6. Protect the vapor valve with a wet rag and braze the vapor line connection to the outdoor unit. The nitrogen flow should be exiting the system from the vapor service port connection. After this connection has cooled, remove the nitrogen source from the liquid fitting service port.
7. Vent the nitrogen holding charge in the outdoor unit by opening both service valves slowly and waiting for the pressure to dissipate. Open both the liquid and vapor valves by removing the plunger cap and with an allen wrench back out counter-clockwise until valve stem just touches the chamfered retaining wall. If the service valve is a ball valve, use a crescent wrench to turn valve stem one-quarter turn counterclockwise to open. Do not overturn or the valve stem may break or become damaged. See "PRECAUTIONS DURING BRAZING SERVICE VALVE".
8. Replace the Schrader core in the liquid and vapor valves.
9. Go to SECTION IV or SECTION V for orifice or TXV installation depending on application.
10. Leak test all refrigerant piping connections including the service port flare caps to be sure they are leak tight. DO NOT OVERTIGHTEN (between 40 and 60 inch - lbs. maximum).

NOTICE

Line set and indoor coil can be pressurized to 250 psig with dry nitrogen and leak tested with a bubble type leak detector. Then release the nitrogen charge.

11. Evacuate the entire 500 microns or less.
12. Replace cap on service ports. Do not remove the flare caps from the service ports except when necessary for servicing the system.

CAUTION

Do not connect manifold gauges unless trouble is suspected. Approximately 3/4 ounce of refrigerant will be lost each time a standard manifold gauge is connected.

13. Add the refrigerant charge into the system. Since these units are designed to operate on either R-22 or R-407C, they have been shipped from the factory with a nitrogen holding charge. Refer to the Tabular Data sheets for refrigerant charge quantities.
14. Replace plunger cap finger tight, then tighten an additional 1/12 turn (1/2 hex flat). Cap must be replaced to prevent leaks.

WARNING

Never attempt to repair any brazed connections while the system is under pressure. Personal injury could result.

See "System Charge" section for checking and recording system charge.

Supplied with the outdoor unit is an Orifice for highest sales volume indoor coil.

SECTION IV: ORIFICE INSTALLATION

Install Orifice as follows:

- Loosen and remove the liquid line fitting from the orifice distributor assembly. Note that the fitting has right hand threads.
- Install proper size orifice supplied with outdoor unit. Refer to supplied Tabular Data Sheet for specific orifice size, refrigerant and indoor coil match up.
- After orifice is installed reinstall the liquid line to the top of the orifice distributor assembly. Hand tighten and turn an additional 1/8 turn to seal. Do not over tighten fittings.
- Leak test system.
- Slide indoor coil back into cabinet.

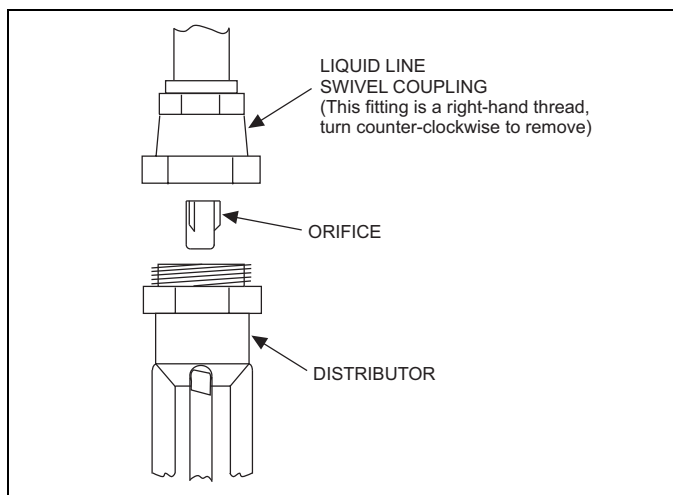

FIGURE 5: Orifice Installation

SECTION V: TXV INSTALLATION

CAUTION

When using a TXV, models with recip compressor require a hard start kit. Models 12-48 with a "H" on the end of the model number have a factory installed hard start.

The following are the basic steps for installation. For detailed instructions, refer to the Installation Instructions accompanying the TXV kit. Install TXV kit as follows:

- Relieve the holding charge by pulling off the rubber cap plug on the suction manifold line of the coil.
- After holding charge is completely discharged, loosen and remove the Schrader cap seal.
- Loosen and remove distributor cap seal.
- Install the thermal expansion valve to the orifice distributor assembly with supplied fittings. Hand tighten and turn an additional 1/4 turn to seal. Do not overtighten fittings.
- Install the liquid line to the top of the thermal expansion valve with fitting supplied with the liquid line. Hand modify the liquid line to align with casing opening. Hand tighten the liquid line and add an additional 1/4 turn to seal.
- Install the TXV equalizer line into the vapor line as follows:
 - Remove black plastic cap on equalizer fitting.
 - Remove schrader valve core with a valve core tool.
 - Hand tighten the 1/4" SAE nut on the TXV to the Schrader fitting and add an additional 1/3 turn to seal.
- Install the TXV bulb to the vapor line near the equalizer line, using the bulb clamp(s) furnished with the TXV assembly. Ensure the bulb is making maximum contact.
 - Bulb should be installed on a horizontal run of the vapor line if possible. The bulb should be installed on top of the line.

- If bulb installation is made on a vertical run, the bulb should be located at least 16" (40.6 cm) from any bend, and on the tubing sides opposite the plane of the bend. The bulb should be positioned with the bulb tail at the top, so that the bulb acts as a reservoir.
- Bulb should be insulated using thermal insulation provided to protect it from the effect of the surrounding ambient temperature. Cover completely to insulate from air-stream.

CAUTION

In all cases, mount the TXV bulb after vapor line is brazed and has had sufficient time to cool.

WARNING

Schrader valve core **MUST NOT** be installed with TXV installation. Poor system performance or system failure could result.

SECTION VI: EVACUATION

It will be necessary to evacuate the system to 500 microns or less. If a leak is suspected, leak test with dry nitrogen to locate the leak. Repair the leak and test again.

To verify that the system has no leaks, simply close the valve to the vacuum pump suction to isolate the pump and hold the system under vacuum. Watch the micron gauge for a few minutes. If the micron gauge indicates a steady and continuous rise, it's an indication of a leak. If the gauge shows a rise, then levels off after a few minutes and remains fairly constant, it's an indication that the system is leak free but still contains moisture and may require further evacuation if the reading is above 500 microns.

SECTION VII: SYSTEM CHARGE

See tabular data sheet provided in unit literature packet for charge requirements. Since these units are designed to operate on either R-22 or R-407C, they have been shipped from the factory with a nitrogen holding charge.

CAUTION

This unit does not contain any refrigerant. It contains a nitrogen holding charge. Operating this unit with the nitrogen holding charge will damage the compressor.

CAUTION

Do not leave the system open to the atmosphere.

The "TOTAL SYSTEM CHARGE" must be permanently stamped on the unit data plate.

Total system charge is determined as follows:

- Determine initial unit charge from tabular data sheet.
- Calculate the line charge using the tabular data sheet if line length is greater than or less than 15 feet (4.6 m).
- Total system charge = item 1 + item 2 .
- Permanently stamp the unit data plate with the total amount of refrigerant in the system.

Use the following charging method whenever additional refrigerant is required for the system charge.

CAUTION

Refrigerant charging should only be carried out by a qualified air conditioning contractor.

CAUTION

Compressor damage will occur if system is improperly charged. On new system installations, charge system per tabular data sheet for the matched coil and follow guidelines in this instruction.

If a calibrated charging cylinder or accurate weighing device is available, add refrigerant accordingly. Otherwise, model-specific charging charts are provided on the access panel of the unit.

SUPERHEAT CHARGING METHOD - PISTON INDOOR

1. Set the system running in cooling mode by setting the thermostat at least 6°F below the room temperature and operate system for at least 10 – 15 minutes.
2. Refer to the technical guide for the recommended airflow and verify indoor airflow (it should be about 400 SCFM per ton).
3. Measure and record the outdoor ambient (DB) temperature and the suction pressure at the suction service valve.
4. Using the charging chart located on the unit, find the intersection of the outdoor ambient dry bulb and the suction pressure obtained in step 3. This is the recommended suction tube temperature at the service valve.
5. Measure and record the suction tube temperature at the service valve and compare to the recommended temperature obtained in step 4.
6. Add charge if the measured suction temperature in step 5 is above the recommended value. Remove / recover refrigerant if the measured suction temperature is below the recommended value.

Example: The suction tube temperature listed on the table at the intersection of the outdoor DB and the suction pressure is 63°F. Temperature of the suction tube at the service valve is 68°F. It would be necessary to add refrigerant to drop the suction tube temperature to 63°F.

SUBCOOLING CHARGING METHOD - TXV INDOOR

1. Set the system running in cooling mode by setting the thermostat at least 6°F below the room temperature and operate system for at least 10 – 15 minutes.
2. Refer to the technical guide for the recommended indoor airflow and verify it is correct (it should be about 400 SCFM per ton).
3. Measure and record the indoor wet bulb (WB) and the outdoor ambient dry bulb (DB) temperature.
4. Using the charging chart located on the unit, find the intersection of the indoor wet bulb and the outdoor dry bulb. This is the recommended liquid pressure (and subcooling value).
5. Measure and record the pressure at the liquid valve pressure port and compare to the value obtained in step 4.
6. Add charge if the measured liquid pressure is lower than the recommended value. Remove / recover charge if the measured liquid pressure is above the recommended value.

Example: The liquid pressure listed at the intersection of the indoor WB and the outdoor DB 320 psig. Pressure at the liquid valve is 305 psig. It would be necessary to add refrigerant to increase the liquid pressure to 320 psig.

Condenser subcooling is obtained by calculating the difference of the saturated refrigerant temperature of the pressure measured at the liquid base valve and the liquid tube temperature as measured at the liquid base valve.

Subcooling Temp. (TC) = Saturated Temp. (TS) – Liquid Temp. (T).

CAUTION

IT IS UNLAWFUL TO KNOWINGLY VENT, RELEASE OR DISCHARGE REFRIGERANT INTO THE OPEN AIR DURING REPAIR, SERVICE, MAINTENANCE OR THE FINAL DISPOSAL OF THIS UNIT.

TABLE 2: R-22 Saturation Properties

Press psig	Temp °F	Press psig	Temp °F	Press psig	Temp °F	Press psig	Temp °F	Press psig	Temp °F	Press psig	Temp °F	Press psig	Temp °F
70	41	100	59	130	74	160	87	190	98	220	108	250	117
72	42	102	60	132	75	162	88	192	99	222	109	252	118
74	44	104	61	134	76	164	88	194	99	224	109	254	118
76	45	106	62	136	77	166	89	196	100	226	110	256	119
78	46	108	63	138	78	168	90	198	101	228	111	258	119
80	48	110	64	140	78	170	91	200	101	230	111	260	120
82	49	112	65	142	79	172	91	202	102	232	112	262	121
84	50	114	66	144	80	174	92	204	103	234	112	264	121
86	51	116	67	146	81	176	93	206	103	236	113	266	122
88	52	118	68	148	82	178	94	208	104	238	114	268	122
90	54	120	69	150	83	180	94	210	105	240	114	270	123
92	55	122	70	152	84	182	95	212	105	242	115	272	123
94	56	124	71	154	84	184	96	214	106	244	115	274	124
96	57	126	72	156	85	186	97	216	107	246	116	276	125
98	58	128	73	158	86	188	97	218	107	248	117	278	125

TABLE 3: R-407C Saturation Properties (Superheat Only)

Press	Temp	Press	Temp	Press	Temp	Press	Temp	Press	Temp	Press	Temp	Press	Temp
psig	°F	psig	°F	psig	°F	psig	°F	psig	°F	psig	°F	psig	°F
70	45	85	55	100	63	115	70	130	77	145	83	160	89
71	46	86	55	101	63	116	70	131	77	146	83	161	89
72	47	87	56	102	64	117	71	132	78	147	84	162	89
73	47	88	56	103	64	118	71	133	78	148	84	163	90
74	48	89	57	104	65	119	72	134	78	149	84	164	90
75	49	90	57	105	65	120	72	135	79	150	85	165	90
76	49	91	58	106	66	121	73	136	79	151	85	166	91
77	50	92	58	107	66	122	73	137	80	152	86	167	91
78	50	93	59	108	67	123	74	138	80	153	86	168	91
79	51	94	60	109	67	124	74	139	80	154	86	169	92
80	52	95	60	110	68	125	74	140	81	155	87	170	92
81	52	96	61	111	68	126	75	141	81	156	87	171	93
82	53	97	61	112	69	127	75	142	82	157	87	172	93
83	53	98	62	113	69	128	76	143	82	158	88	173	93
84	54	99	62	114	69	129	76	144	82	159	88	174	94

TABLE 4: R-407C Saturation Properties (Subcooling Only)

Press	Temp	Press	Temp	Press	Temp	Press	Temp	Press	Temp	Press	Temp	Press	Temp
psig	°F	psig	°F	psig	°F	psig	°F	psig	°F	psig	°F	psig	°F
175	84	190	90	205	95	220	99	235	104	250	108	265	112
176	85	191	90	206	95	221	100	236	104	251	108	266	113
177	85	192	90	207	95	222	100	237	104	252	109	267	113
178	85	193	91	208	95	223	100	238	105	253	109	268	113
179	86	194	91	209	96	224	100	239	105	254	109	269	113
180	86	195	91	210	96	225	101	240	105	255	110	270	114
181	86	196	92	211	96	226	101	241	106	256	110	271	114
182	87	197	92	212	97	227	101	242	106	257	110	272	114
183	87	198	92	213	97	228	102	243	106	258	110	273	114
184	87	199	93	214	97	229	102	244	106	259	111	274	115
185	88	200	93	215	98	230	102	245	107	260	111	275	115
186	88	201	93	216	98	231	103	246	107	261	111	276	115
187	88	202	94	217	98	232	103	247	107	262	111	277	116
188	89	203	94	218	99	233	103	248	108	263	112	278	116
189	89	204	94	219	99	234	104	249	108	264	112	279	116

SECTION VIII: ELECTRICAL CONNECTIONS

GENERAL INFORMATION & GROUNDING

Check the electrical supply to be sure that it meets the values specified on the unit nameplate and wiring label.

Power wiring, control (low voltage) wiring, disconnect switches and over current protection must be supplied by the installer. Wire size should be sized per NEC requirements.

CAUTION

All field wiring must USE COPPER CONDUCTORS ONLY and be in accordance with Local, National, Fire, Safety & Electrical Codes. This unit must be grounded with a separate ground wire in accordance with the above codes.

The complete connection diagram and schematic wiring label is located on the inside surface of the unit service access panel.

FIELD CONNECTIONS POWER WIRING

1. Install the proper size weatherproof disconnect switch outdoors and within sight of the unit.
2. Remove the screws at the top and sides of the corner cover. Slide corner cover down and remove from unit.
3. Run power wiring from the disconnect switch to the unit.
4. Route wires from disconnect through power wiring opening provided and into the unit control box as shown in Figures 6 & 7.
5. Install the proper size time-delay fuses or circuit breaker, and make the power supply connections.

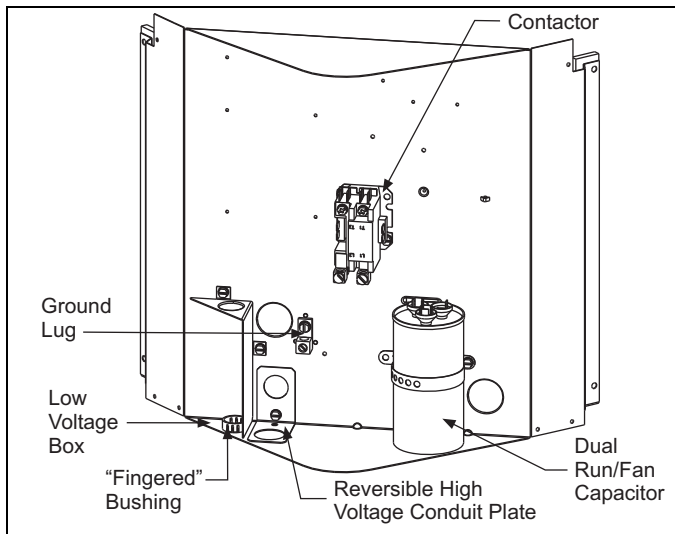

FIGURE 6: Outdoor Unit Control Box (Single Phase)

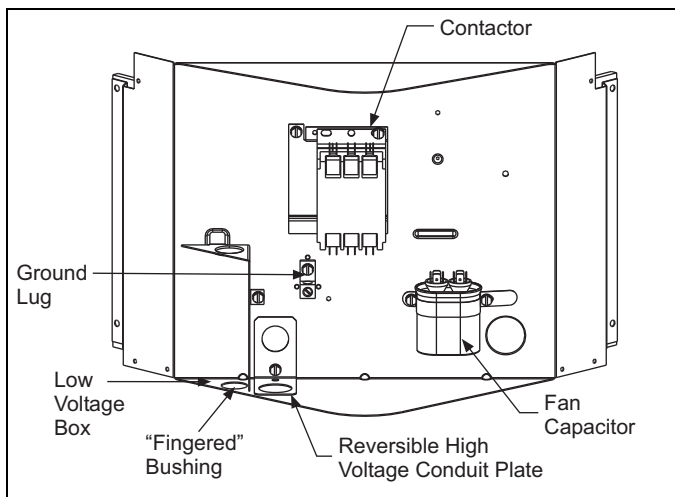

FIGURE 7: Outdoor Unit Control Box (Three Phase - GCGA36-60)

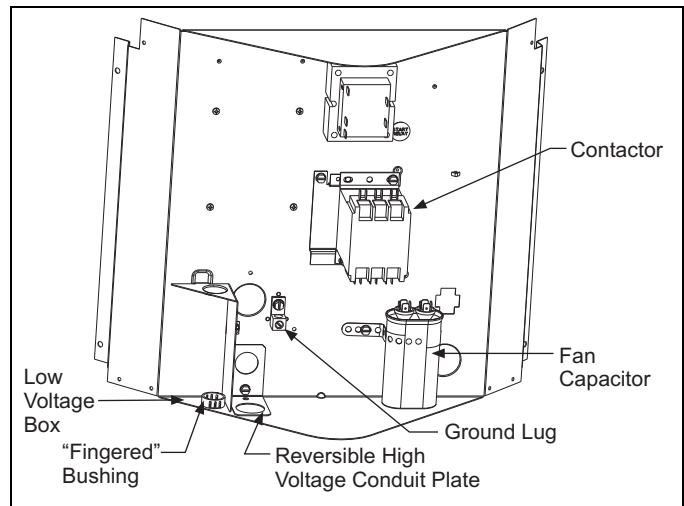

FIGURE 8: Outdoor Unit Control Box (GCGA76 With Transformer)

FIELD CONNECTIONS CONTROL WIRING

1. Route low voltage wiring into bottom of control box as shown in Figure 6. Make low voltage wiring connections inside the low voltage box per Figures 7 - 11.
2. The complete connection diagram and schematic wiring label is located on the inside surface of the unit service access panel.
3. Replace the corner cover removed in Step 2.
4. All field wiring to be in accordance with national electrical codes (NEC) and/or local-city codes.

NOTE: A Start Assist Kit is available and recommended for long line set applications or in areas of known low voltage problems.

5. Mount the thermostat about 5 ft. above the floor, where it will be exposed to normal room air circulation. Do not place it on an outside wall or where it is exposed to the radiant effect from exposed glass or appliances, drafts from outside doors or supply air grilles.
6. Route the 24-volt control wiring (NEC Class 2) from the outdoor unit to the indoor unit and thermostat.

NOTICE

To eliminate erratic operation, seal the hole in the wall at the thermostat with permagum or equivalent to prevent air drafts affecting the operation of in the thermostat.

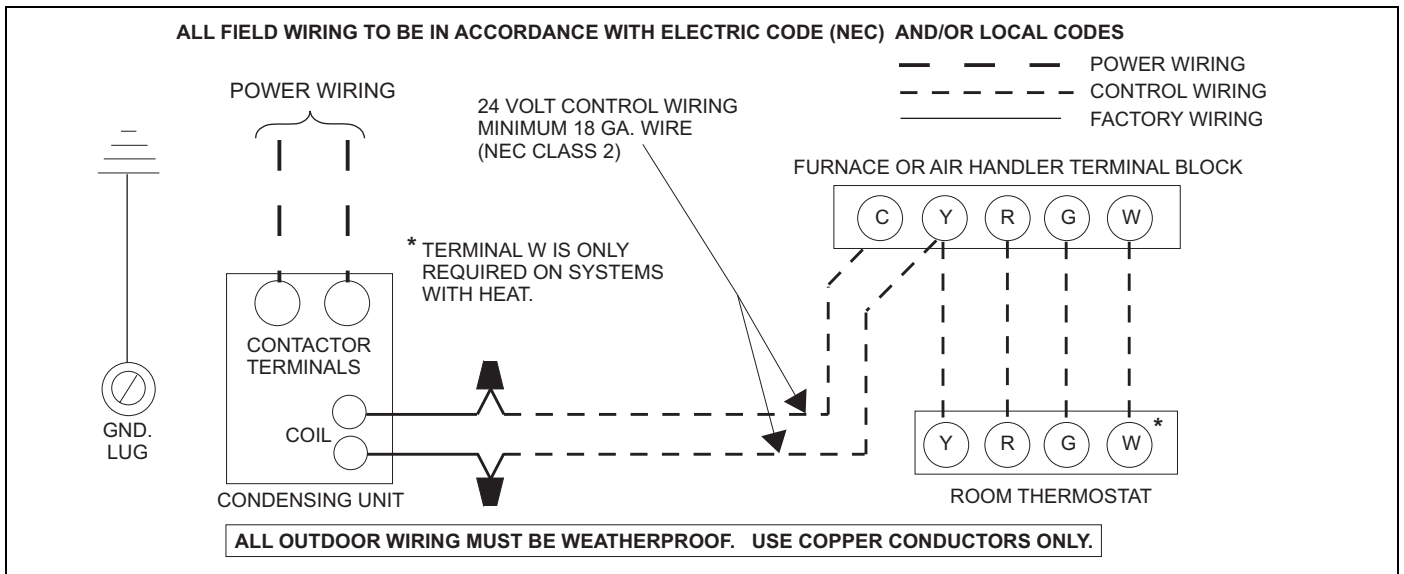

FIGURE 9: Typical Field Wiring (Air Handler / Electrical Heat) (Single-Phase)

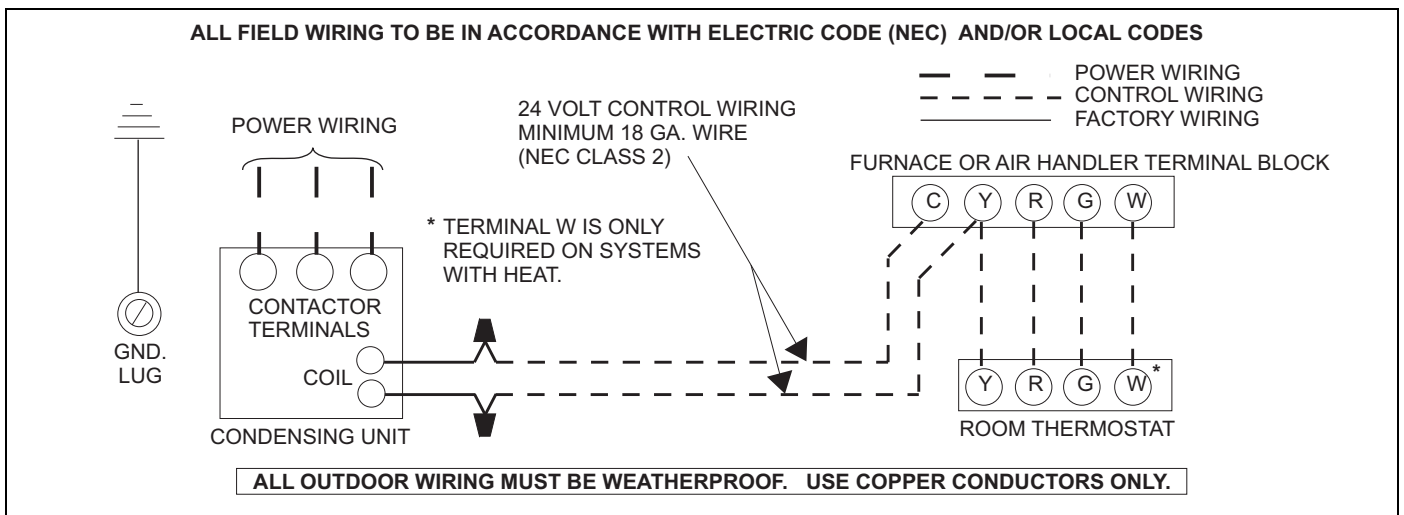

FIGURE 10: Typical Field Wiring (Air Handler / Electrical Heat) (Three Phase - GCGA36-60)

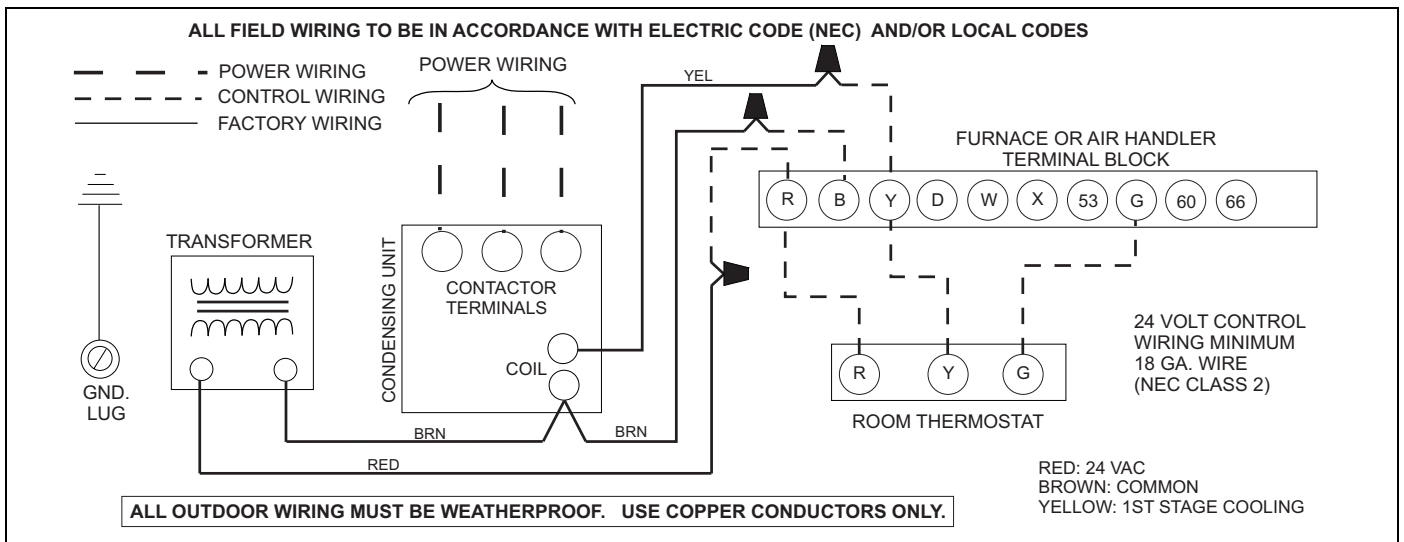

FIGURE 11: Typical Field Wiring for 76 Models with Air Handler (Three-Phase - GCGA76)

For additional connection diagrams for all UPG equipment refer to "Low Voltage System Wiring" document available online at www.upgnet.com in the Product Catalog Section.

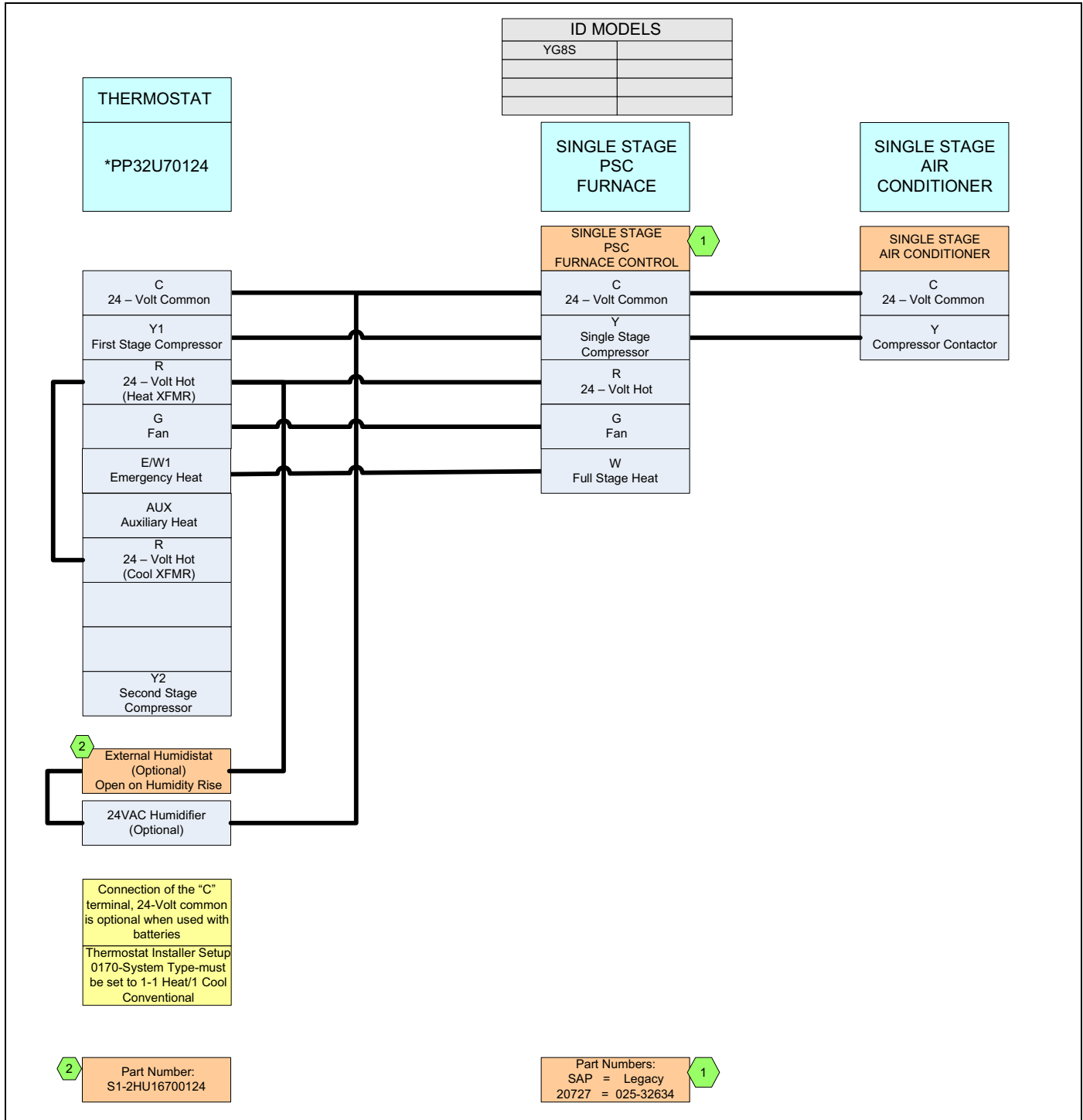

FIGURE 12: Thermostat Chart - Single Stage AC with PSC Furnace

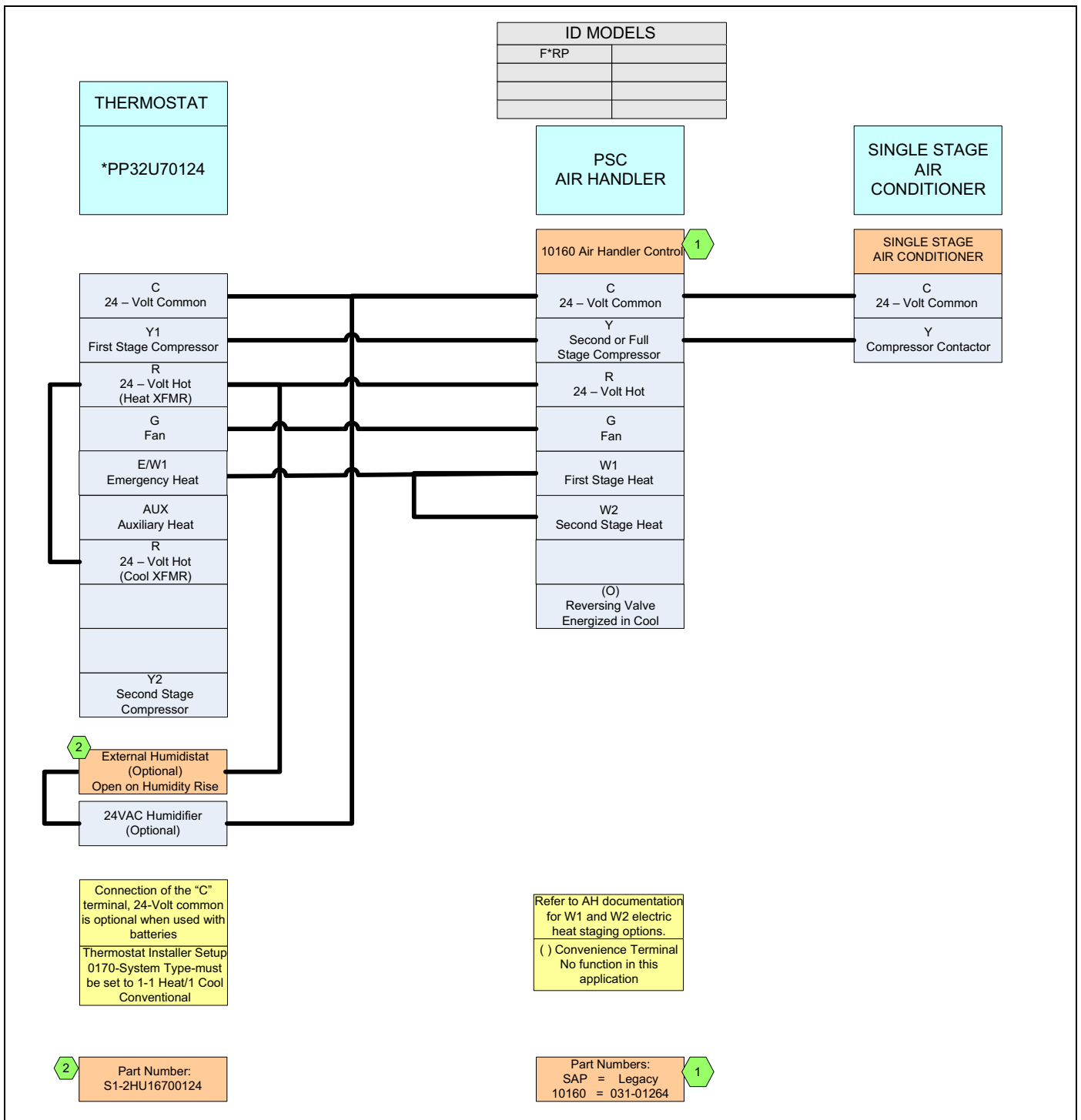

FIGURE 13: Thermostat Chart - Single Stage AC with PSC Air Handler

SECTION IX: INSTRUCTING THE OWNER

Assist owner with processing warranty cards and/or online registration. Review Owners Guide and provide a copy to the owner and guidance on proper operation and maintenance. Instruct the owner or the operator how to start, stop and adjust temperature setting.

When applicable, instruct the owner that the compressor is equipped with a crankcase heater to prevent the migration of refrigerant to the compressor during the OFF cycle. The heater is energized only when the unit is not running. If the main switch is disconnected for long periods of shut down, do not attempt to start the unit until 8 hours after the switch has been connected. This will allow sufficient time for all liquid refrigerant to be driven out of the compressor.

The installer should also instruct the owner on proper operation and maintenance of all other system components.

MAINTENANCE

1. Dirt should not be allowed to accumulate on the outdoor coils or other parts in the air circuit. Clean as often as necessary to keep the unit clean. Use a brush, vacuum cleaner attachment, or other suitable means.
2. The outdoor fan motor is permanently lubricated and does not require periodic oiling.

3. If the coil needs to be cleaned, use clean water to wash dust, dirt, and debris from outdoor condensing coil.

NOTICE

DO NOT use coil cleaners to clean outdoor condensing coil. cleaners containing HF-, hydroxides, chlorides, and sulfates can greatly reduce the lifetime of the aluminum condensing coil.

4. Refer to the furnace or air handler instructions for filter and blower motor maintenance.
5. The indoor coil and drain pan should be inspected and cleaned regularly to prevent odors and assure proper drainage.

CAUTION

IT IS UNLAWFUL TO KNOWINGLY VENT, RELEASE OR DISCHARGE REFRIGERANT INTO THE OPEN AIR DURING REPAIR, SERVICE, MAINTENANCE OR THE FINAL DISPOSAL OF THIS UNIT.

SECTION X: WIRING DIAGRAM

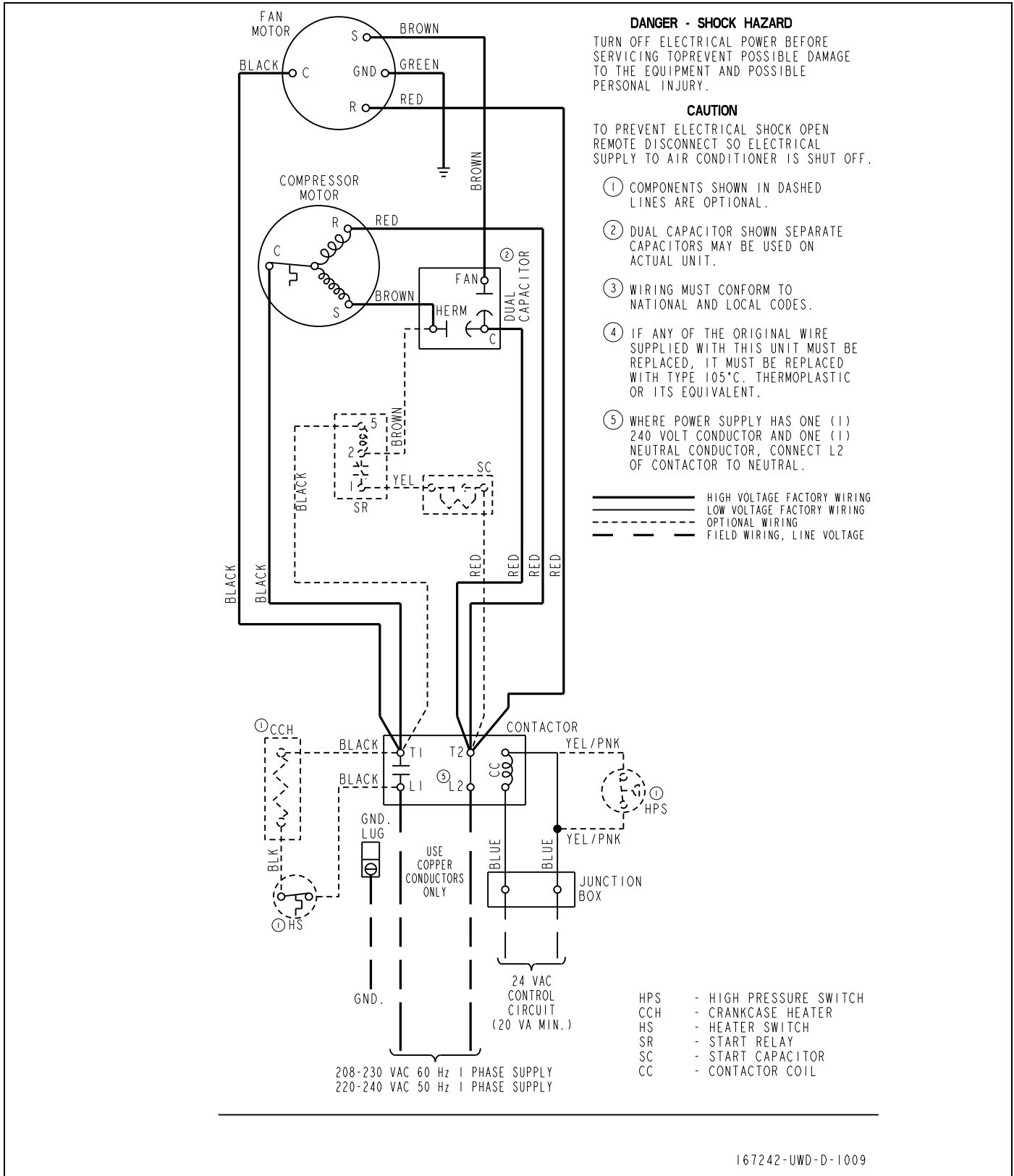

FIGURE 14: Wiring Diagram - Single Phase

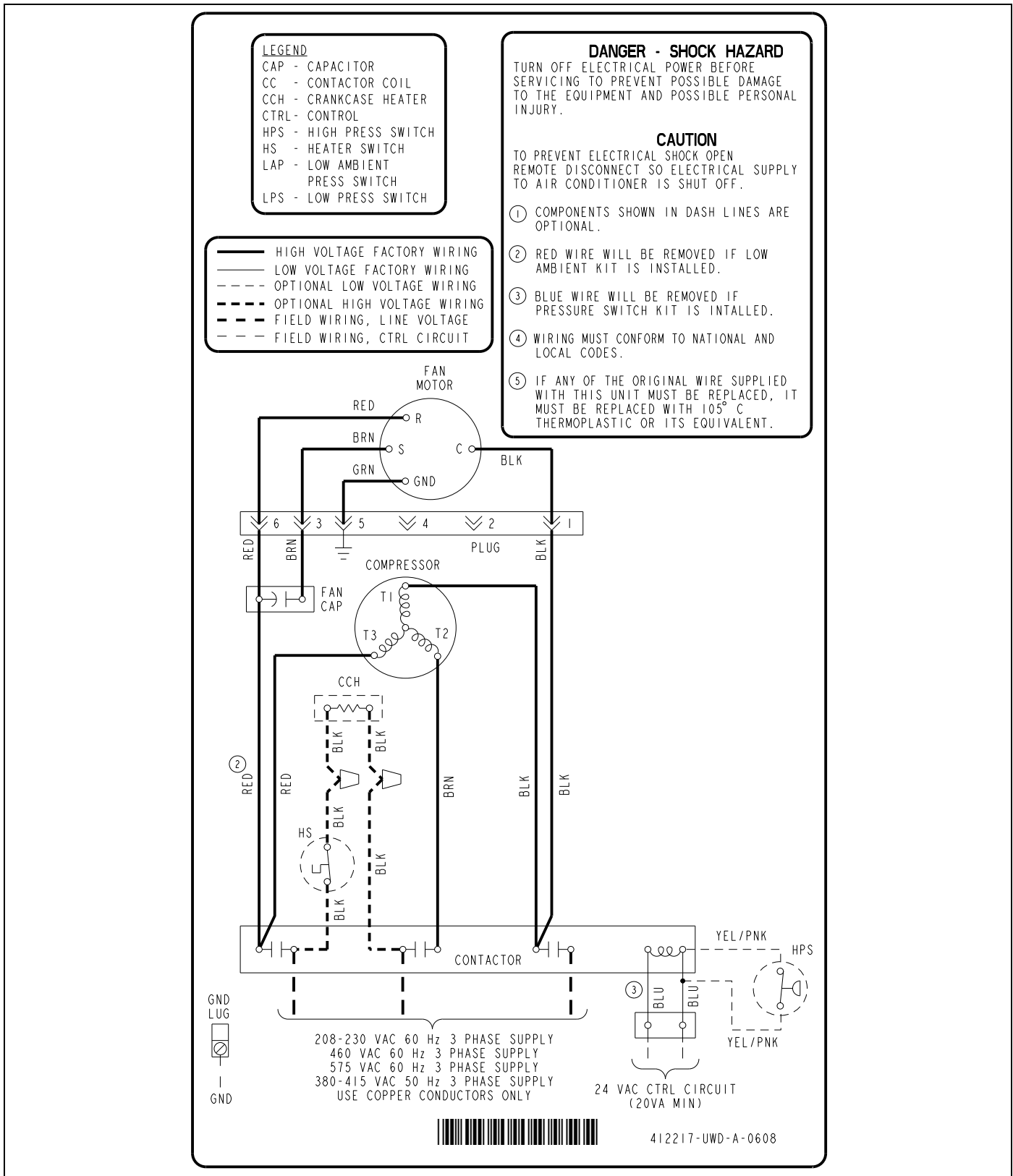

FIGURE 15: Wiring Diagram - Three Phase - GCGA36-60

- ① COMPONENTS SHOWN IN DASHED LINES ARE OPTIONAL.
- ② RED WIRE WILL BE REMOVED IF LOW AMBIENT KIT IS INSTALLED.
- ③ YELLOW WIRE WILL BE REMOVED IF PRESSURE SWITCH KIT IS INSTALLED.
- ④ IF ANY OF THE ORIGINAL WIRE SUPPLIED WITH THIS UNIT MUST BE REPLACED, IT MUST BE REPLACED WITH TYPE 105° C, THERMOPLASTIC OR ITS EQUIVALENT.
- ⑤ WIRING MUST CONFORM TO NATIONAL AND LOCAL CODES.

HPS -HIGH PRESSURE SWITCH
 LP -LOW PRESSURE SWITCH
 LAP -LOW AMBIENT PRESSURE SWITCH
 CCH -CRANKCASE HEATER
 CC -CONTACTOR COIL
 ASCT -ANTI-SHORT CYCLE TIME

DANGER - SHOCK HAZARD
 TURN OFF ELECTRICAL POWER BEFORE
 SERVICING TO PREVENT POSSIBLE DAMAGE
 TO THE EQUIPMENT AND POSSIBLE
 PERSONAL INJURY.

CAUTION
 TO PREVENT ELECTRICAL SHOCK OPEN
 REMOTE DISCONNECT SO ELECTRICAL
 SUPPLY TO AIR CONDITIONER IS SHUT OFF.

———— HIGH VOLTAGE FACTORY WIRING
 = = = = LOW VOLTAGE FACTORY WIRING
 ———— FIELD WIRING, LINE VOLTAGE
 - - - - OPTIONAL WIRING

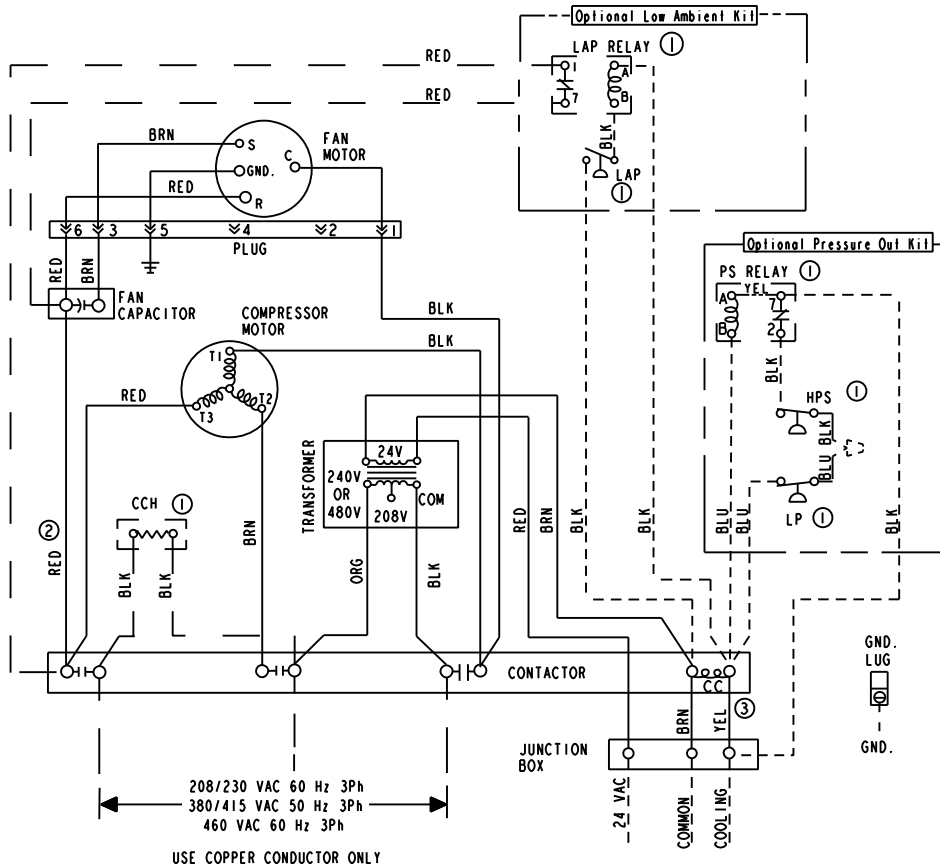

208/230 VAC 60 Hz 3Ph
 380/415 VAC 50 Hz 3Ph
 460 VAC 60 Hz 3Ph

USE COPPER CONDUCTOR ONLY



18661/035-15843-502-B-0110

FIGURE 16: Wiring Diagram - Three Phase - GCGA76

NOTES